

# Space-Based Exoplanet Microlensing Surveys

David Bennett  
University of Notre Dame

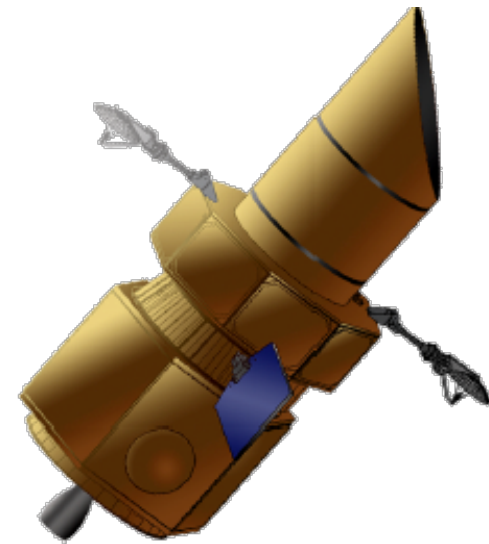
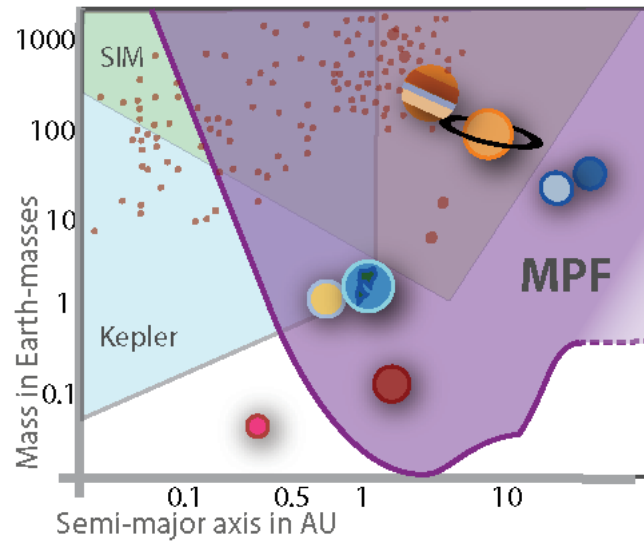
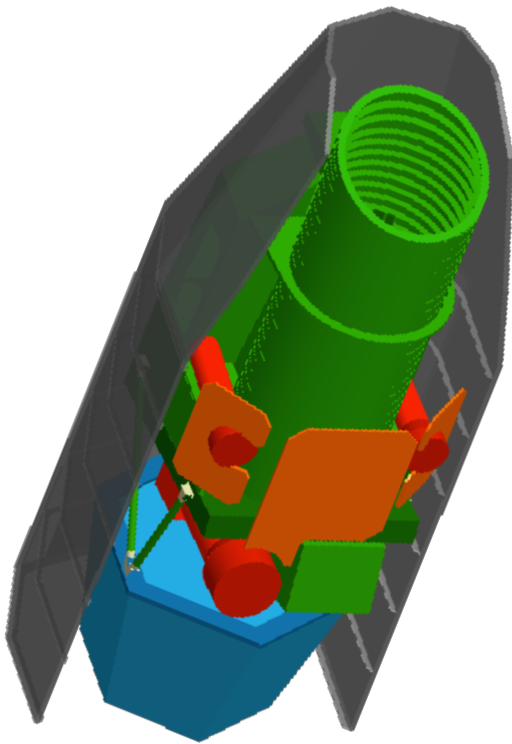

# The Physics of Microlensing

- Foreground “lens” star + planet bend light of “source” star
- Multiple distorted images
  - Only total brightness change is observable
- Sensitive to planetary mass
- Low mass planet signals are rare – not weak
- Stellar lensing probability  $\sim a \text{ few } \times 10^{-6}$ 
  - Planetary lensing probability  $\sim 0.001-1$  depending on event details
- Peak sensitivity is at 2-3 AU: the Einstein ring radius,  $R_E$

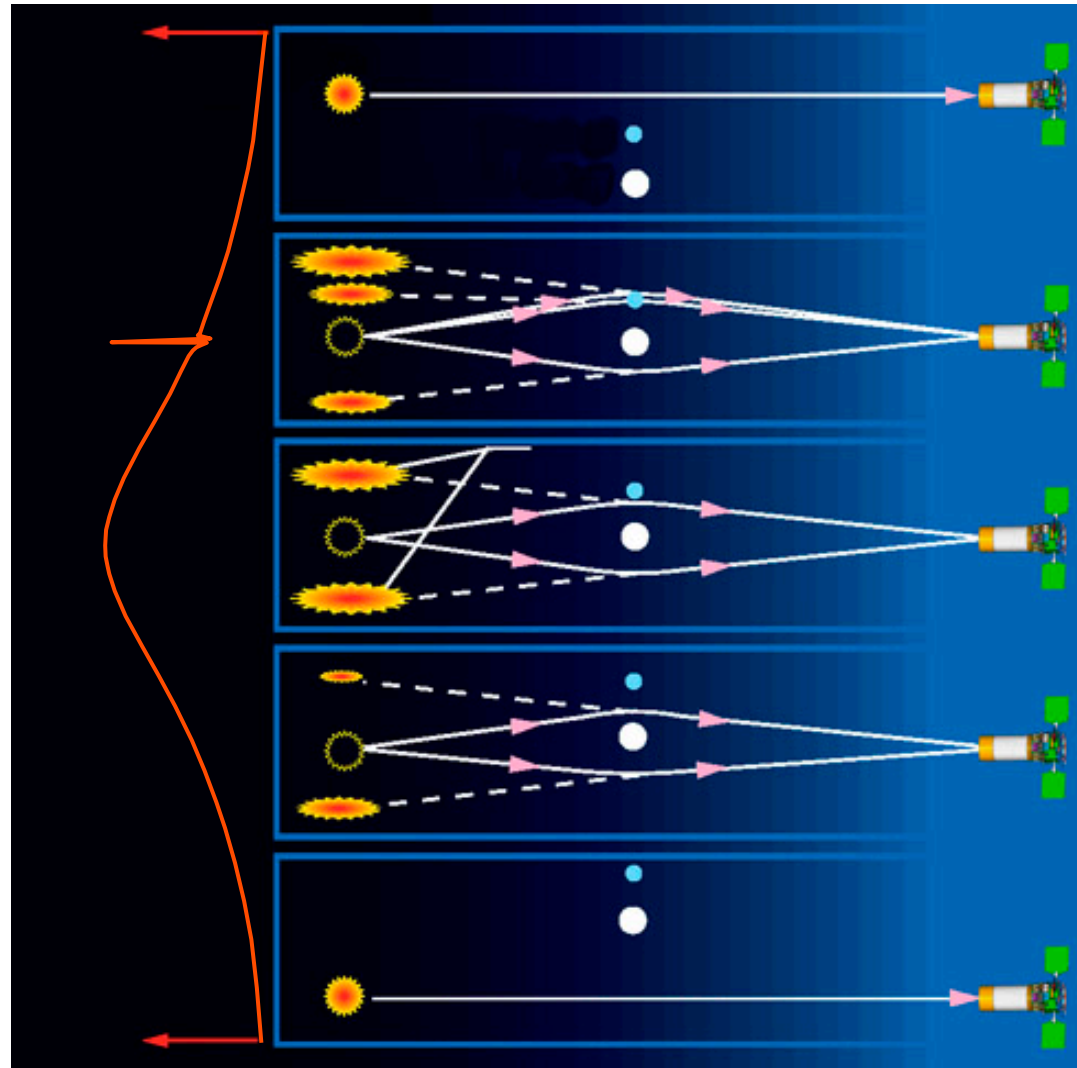

Key Fact:  $1 \text{ AU} \approx \sqrt{R_{Sch} R_{GC}} = \sqrt{\frac{2GM}{c^2} R_{GC}}$

# Microlensing Target Fields are in the Galactic Bulge

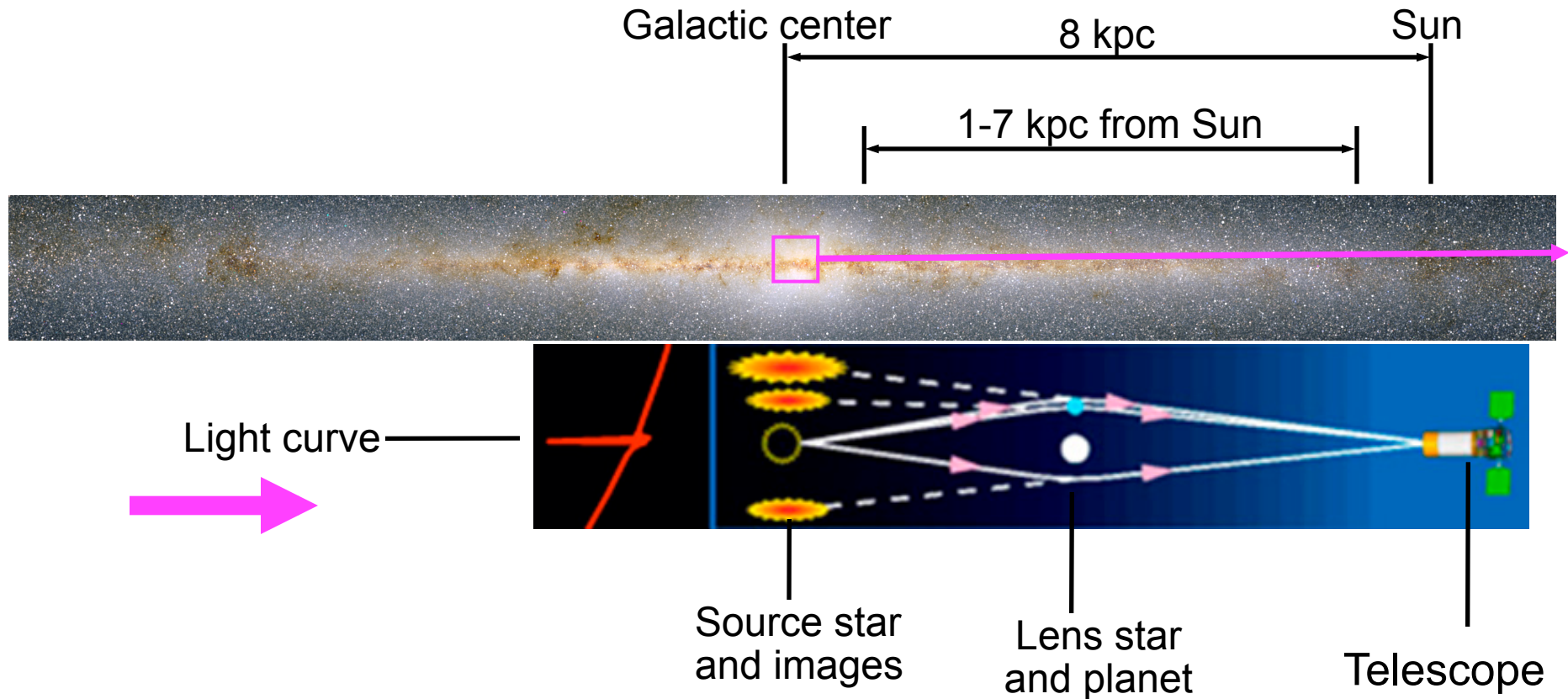

**10s of millions of stars in the Galactic bulge in order to detect planetary companions to stars in the Galactic disk and bulge.**

# Extraction of Exoplanet Signal

Time-series photometry is combined to uncover light curves of background source stars being lensed by foreground stars in the disk and bulge.

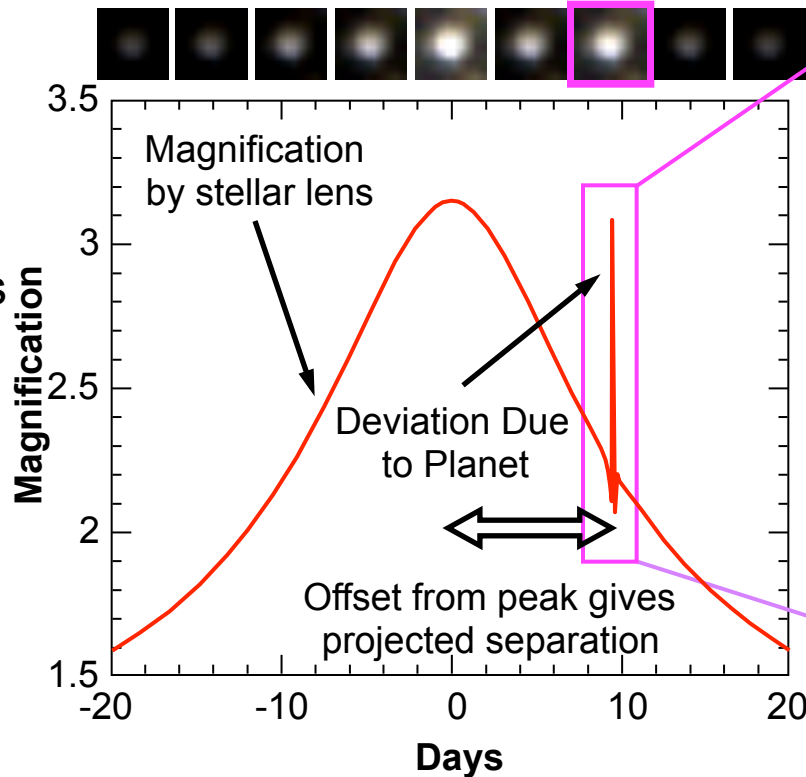

Planets are revealed as short-duration deviations from the smooth, symmetric magnification of the source due to the primary star.

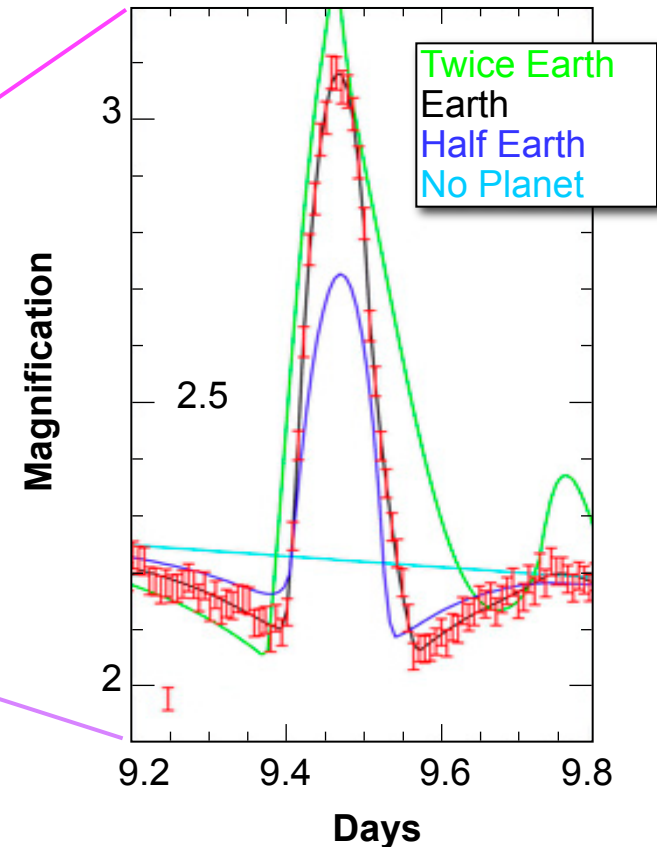

Detailed fitting to the photometry yields the parameters of the detected planets.

# How Low Can We Go?

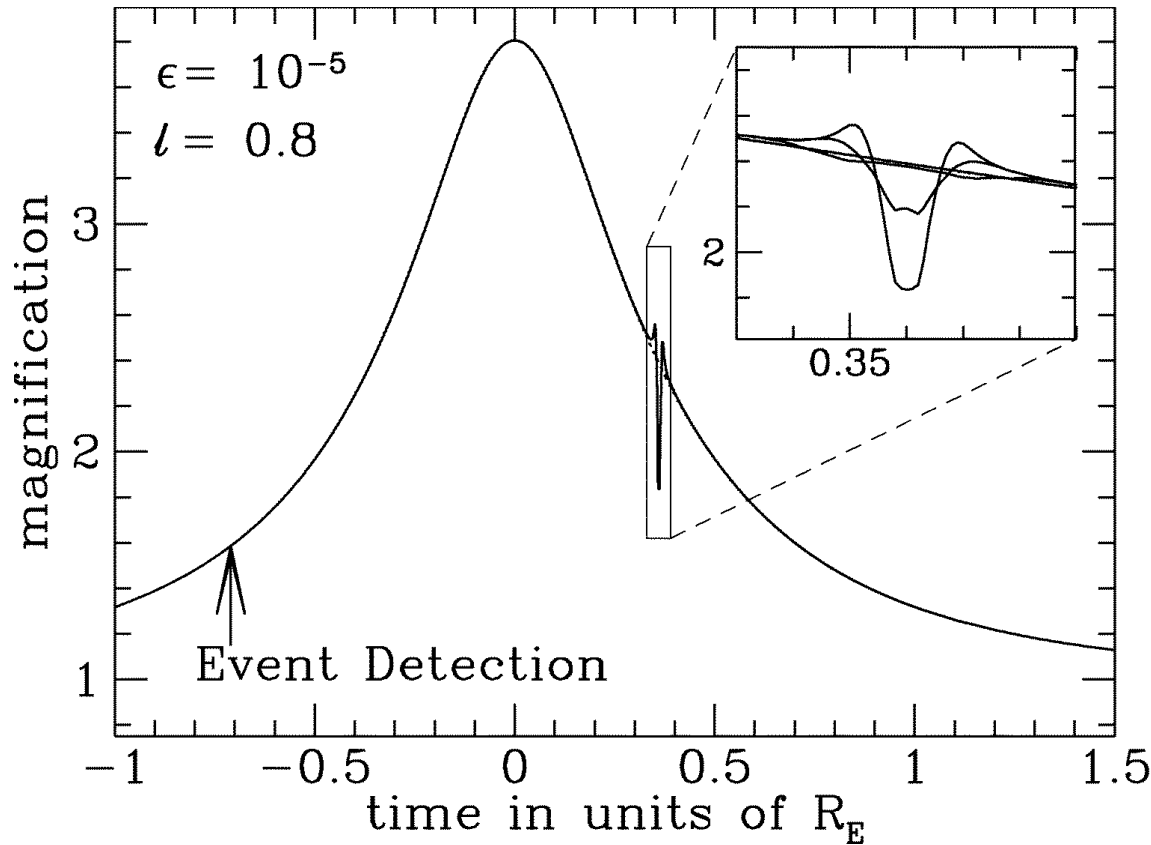

(Bennett & Rhie 1996)

For  $\theta_E \geq \theta_*$  :  
low-mass planet signals are rare  
and brief, but not weak

Limited by Source Size

angular Einstein radius

$$\theta_E \approx \mu \text{as} \left( \frac{M_P}{M_\oplus} \right)^{1/2}$$



$$\theta_* \approx \mu \text{as} \left( \frac{R_*}{R_\odot} \right)$$

angular source star radius

**Mars-mass planets  
detectable  
if solar-type sources can be  
monitored!**

# Why Space-based Microlensing?

- Microlensing requires extremely crowded fields
- Source stars only resolvable from space
- Ground-based surveys need high lensing magnification to resolve most source stars
  - Limits sensitivity to near the Einstein ring
  - Space-based microlensing sensitive from 0.5 AU -  $\infty$
- Space-based microlensing allows detection of most lens stars
  - Allows direct determination of star and planet masses
- Simulations from Bennett & Rhie (2002)
- Basic results confirmed by independent simulations (Gaudi)
- MPF Discovery proposal (2006) -> WFIRST

# Unique Science from Space-based Survey

- Exoplanet sensitivity down to sub-Earth masses at 0.5 AU -  $\infty$ 
  - down to 0.1 Earth-masses over most of this range
    - approximate planetary embryo size
  - complementary to Kepler
  - free-floating planets down to 0.1 Earth-masses
    - free-floating planet mass distribution is important for understanding planet formation.
- Most host stars can be detected in space-based data
  - provides host star and planet masses and separations instead of just mass ratios and separations in Einstein radius units.
  - ground-based surveys don't usually get more than mass ratio
- Planetary properties as a function of Galactocentric radius
  - generally requires lens star detection

# Ground-based confusion, space-based resolution

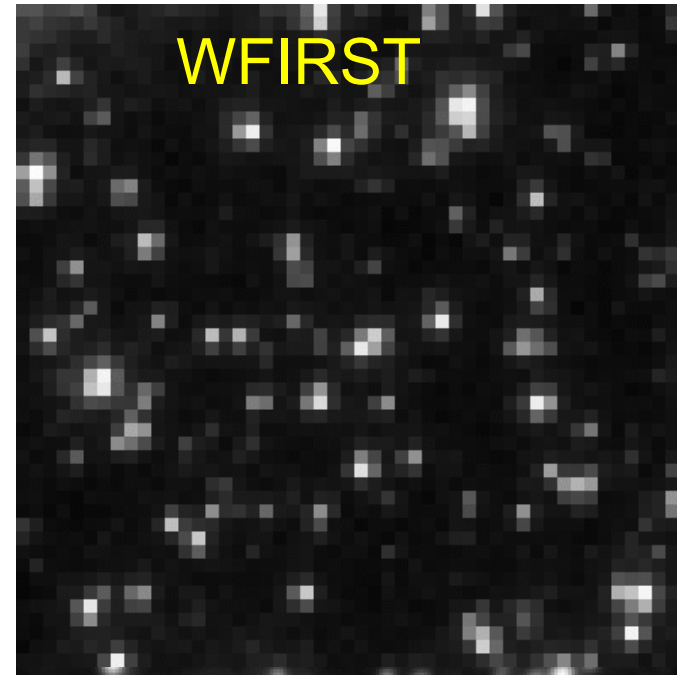
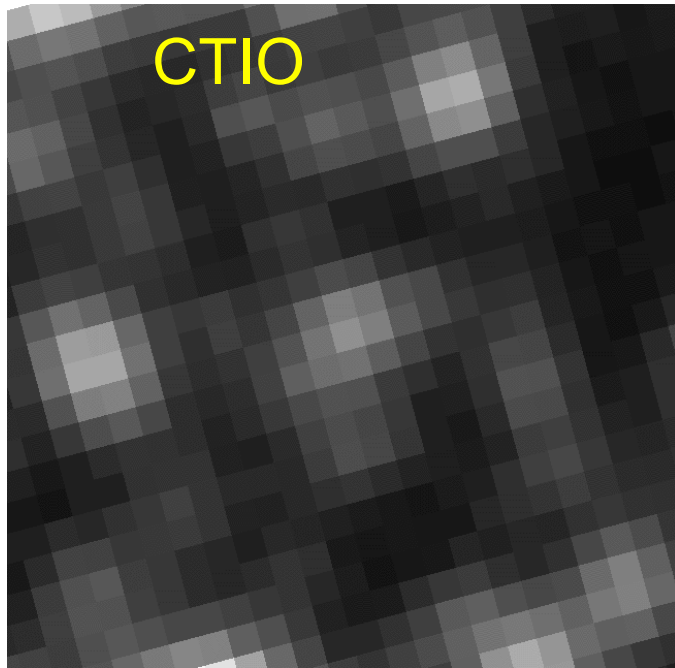

- Space-based imaging needed for high precision photometry of main sequence source stars (at low magnification) and lens star detection
- High Resolution + large field + 24hr duty cycle => Space-based Microlensing Survey
- Space observations needed for sensitivity at a range of separations and mass determinations



# High-magnification: Low-mass planets

OGLE-2005-BLG-169Lb

- Detection of a  $\sim 13 M_{\oplus}$  planet in a  $A_{\max} = 800$  event
- Caustic crossing signal is obvious when light curve is divided by a single lens curve.
- Detection efficiency for  $\sim 10 M_{\oplus}$  planets is  $\ll$  than for Jupiter-mass planets
- Competing models with an Earth-mass planet had a signal of similar amplitude
- So, an Earth-mass planet could have been detected in this event!

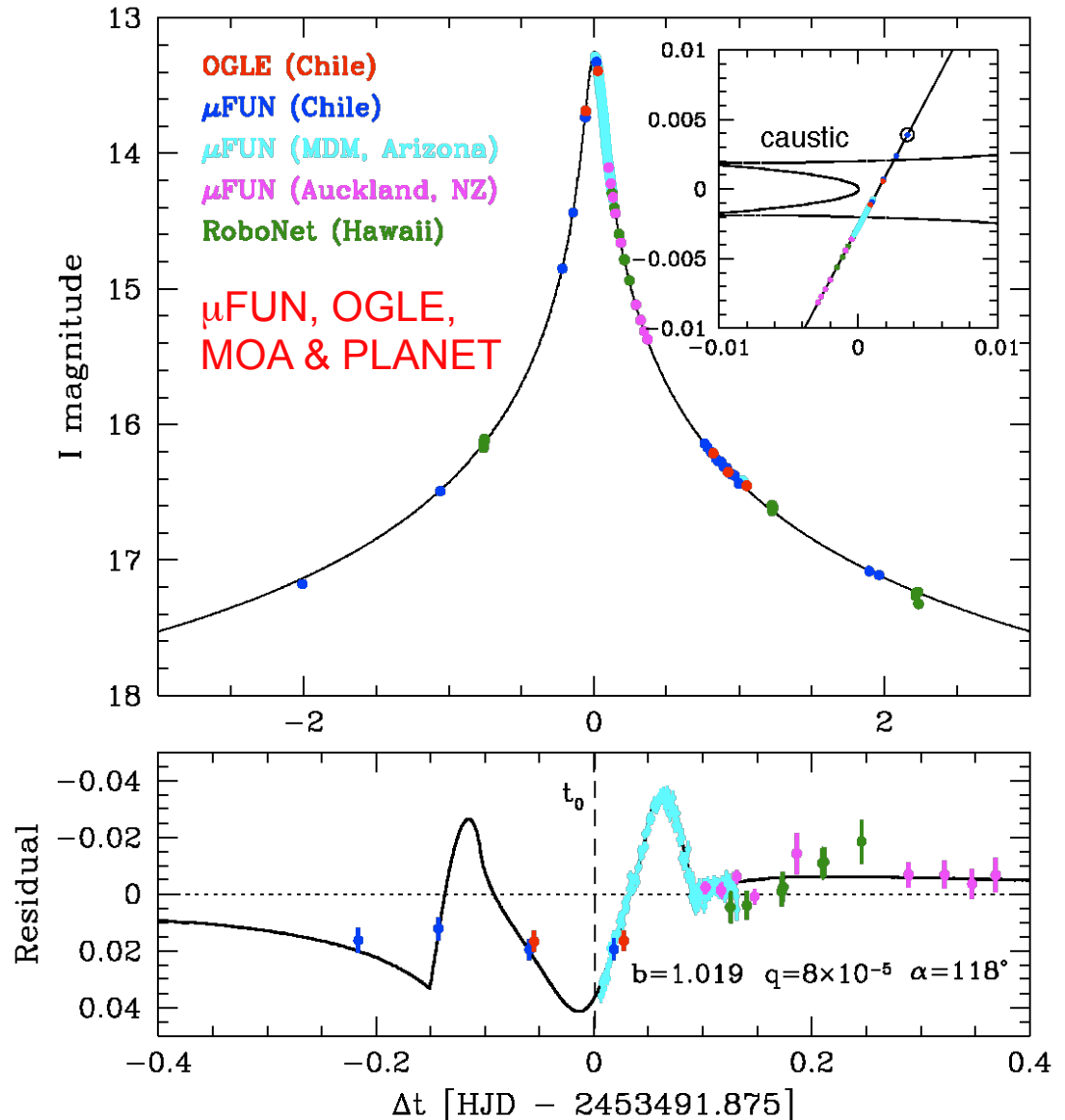

# Planet Discoveries by Method

- ~400 Doppler discoveries in black
- Transit discoveries are blue squares
- Gravitational microlensing discoveries in red
  - cool, low-mass planets
- Direct detection, and timing are magenta and green triangles
- Kepler candidates are cyan spots

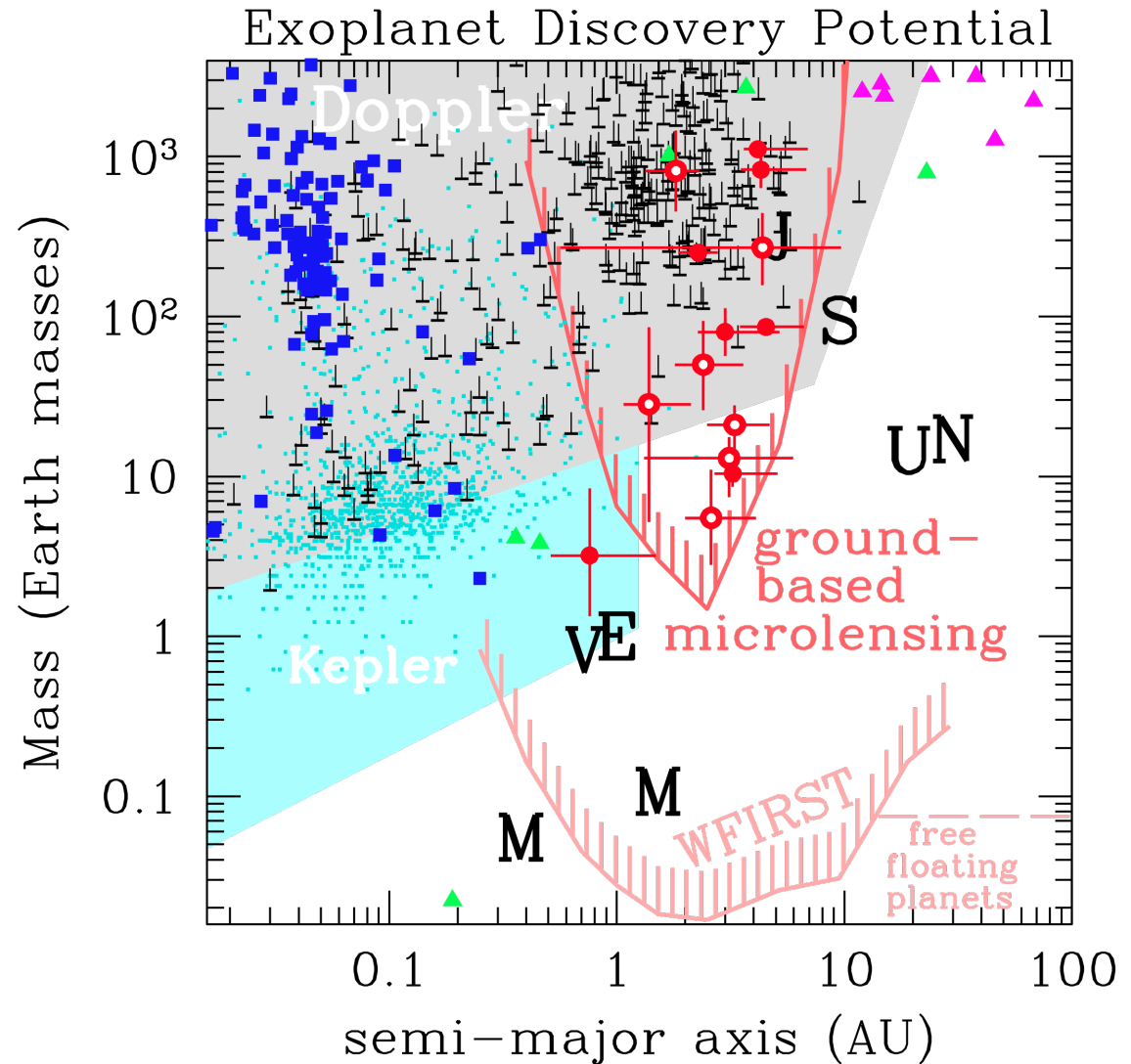

# Space vs. Ground Sensitivity

## Exoplanet Discovery Potential

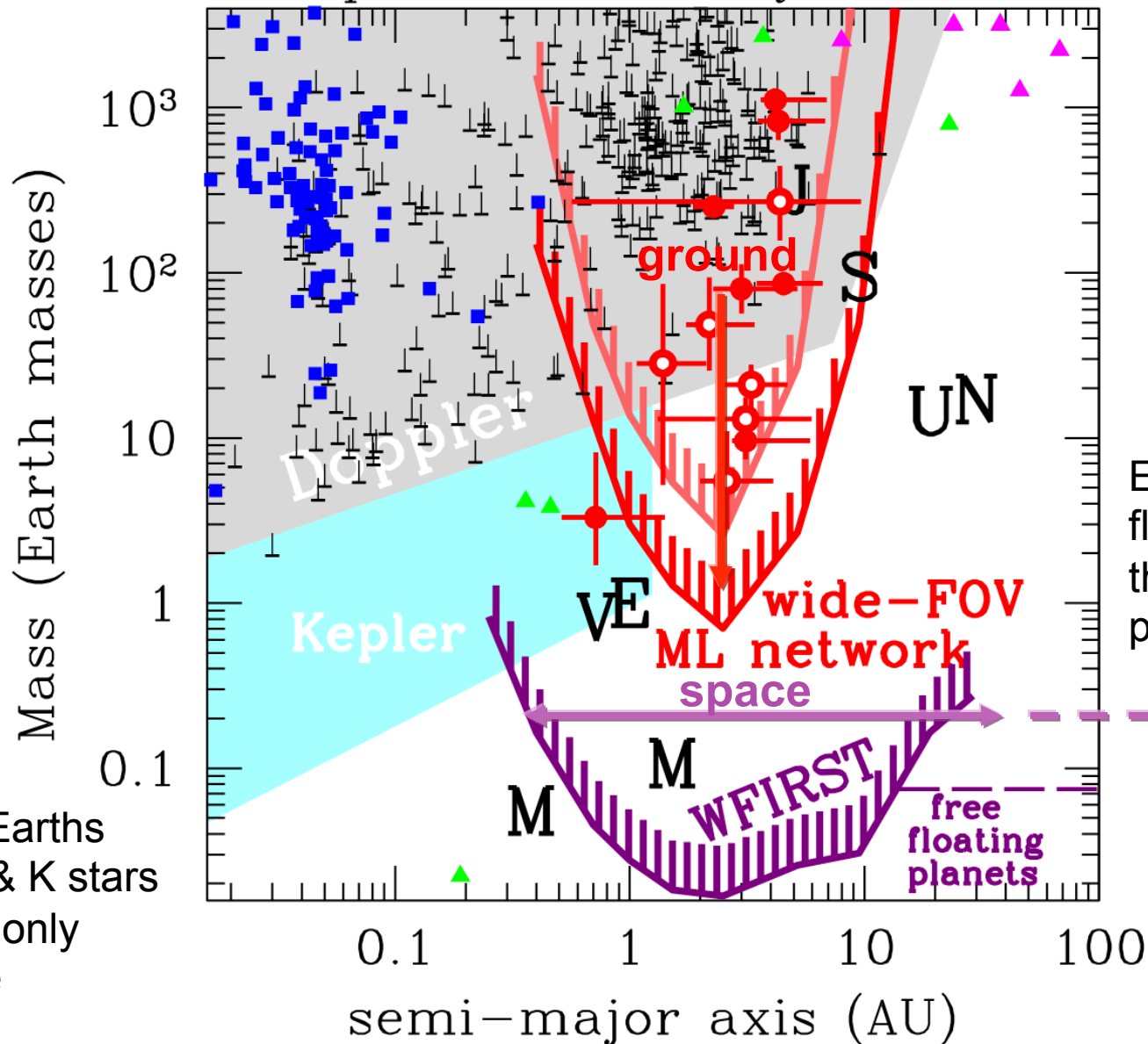

Habitable Earths orbiting G & K stars accessible only from space

# WFIRST vs. Kepler

WFIRST – w/ extended mission

Kepler ~12 yr mission

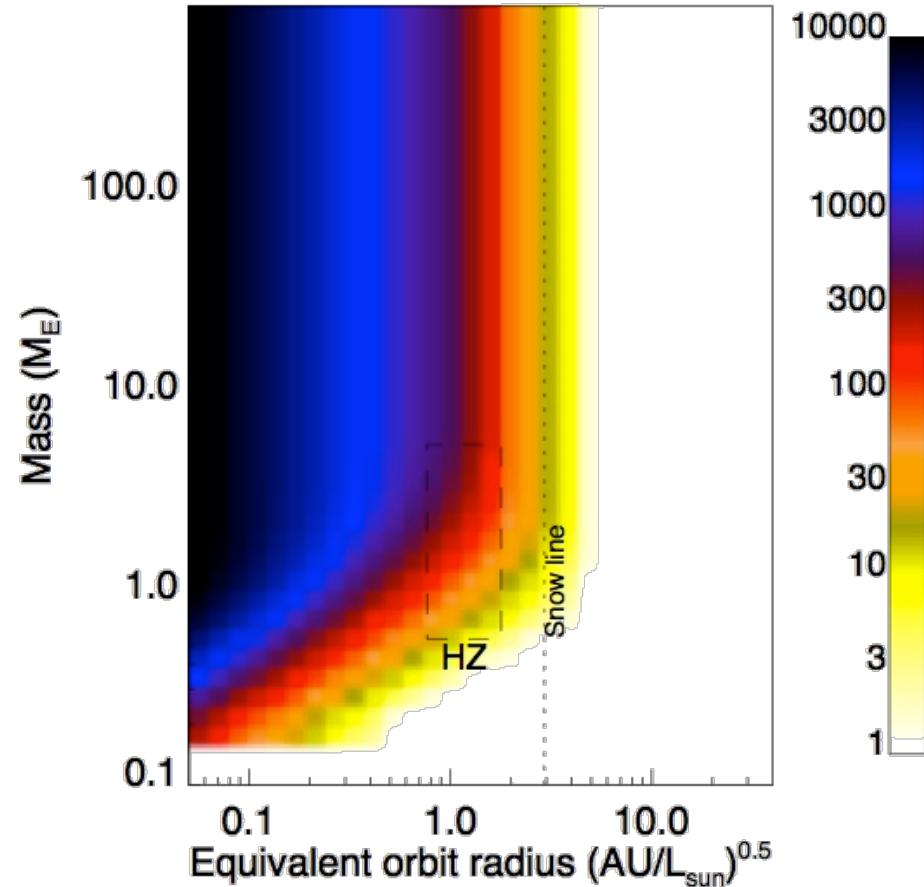
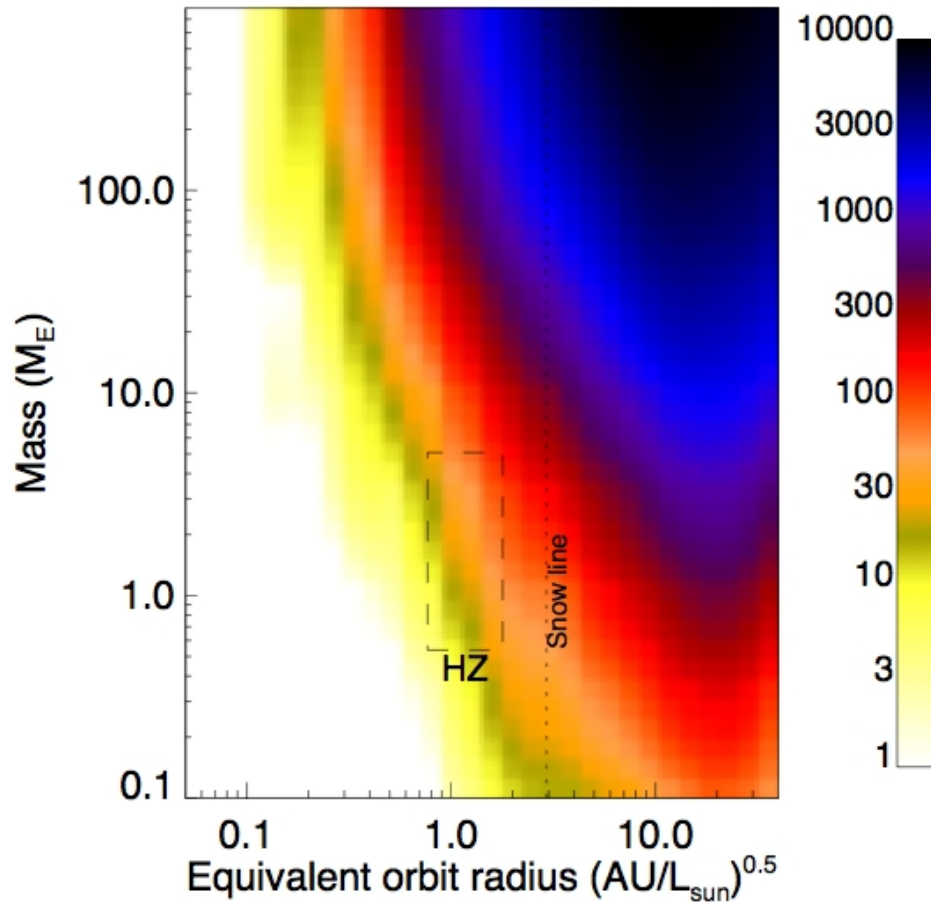

Figures from B. MacIntosh of the ExoPlanet Task Force

# Infrared Observations Are Best

The central Milky Way:  
near infrared

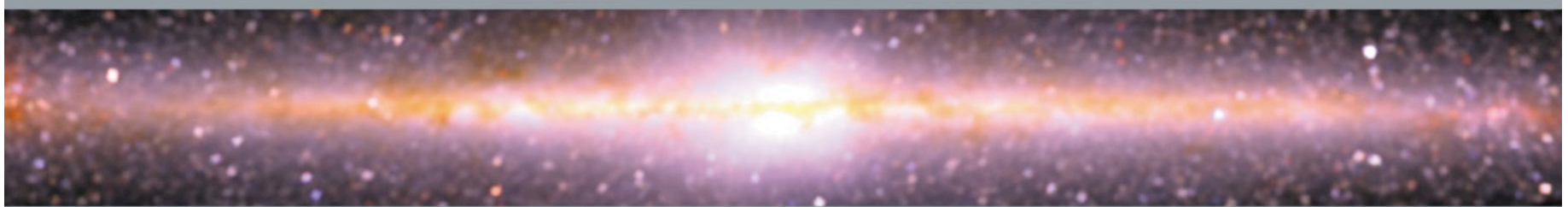

optical

Dust obscures the best microlensing fields toward the center of the Galaxy

# Detector Sensitivity

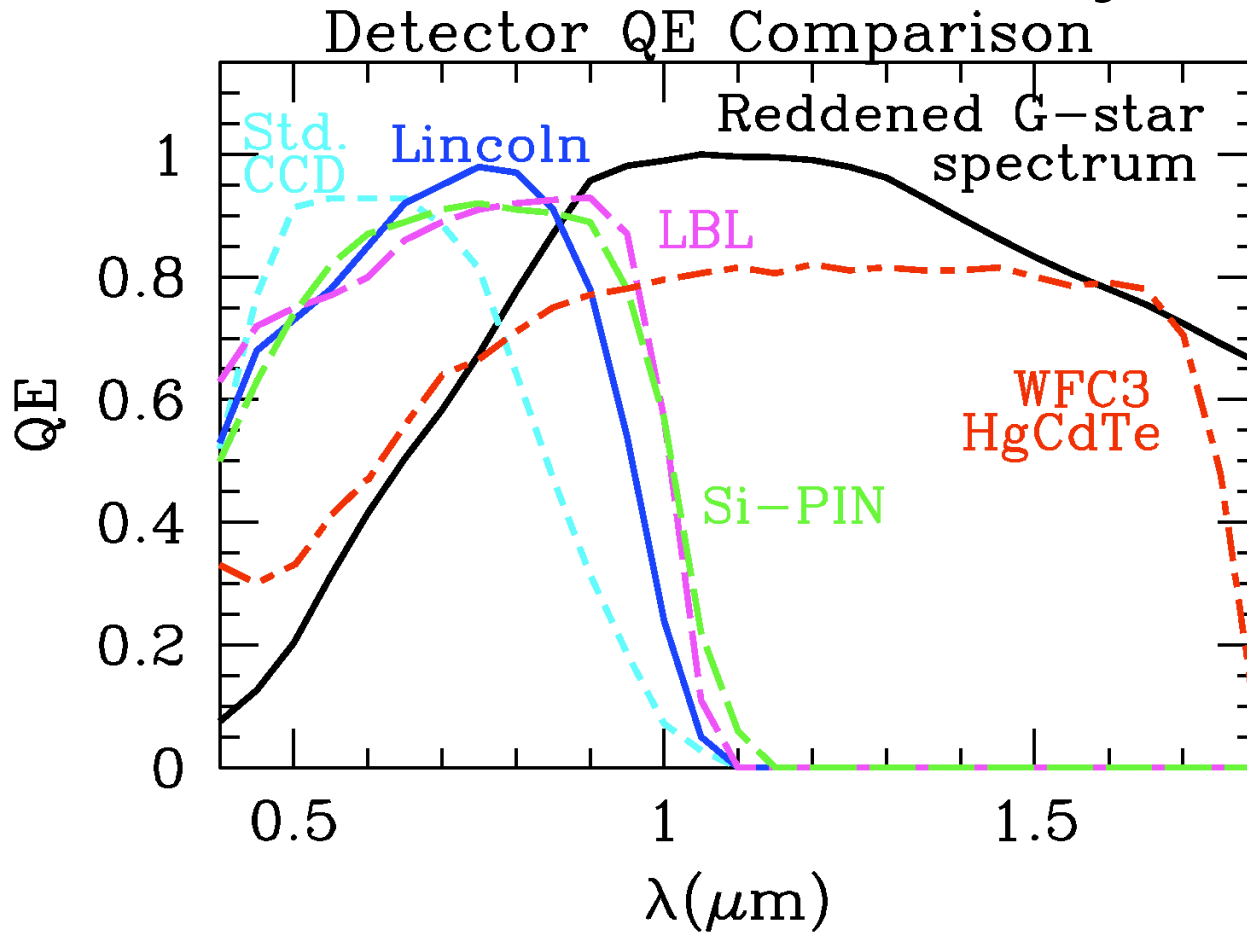

The spectrum of a typical reddened source star is compared to the QE curves of CCDs and Si-PIN detector arrays. The HgCdTe detectors developed for HST's WFC3 instrument can detect twice as many photons as the most IR sensitive Si detectors (CCDs or CMOS). MPF will employ 35 HgCdTe detectors. 3 filters: "clear" 600-1700nm, "visible" 600-900nm, and "IR" 1300-1700nm.

# Space Mission Requirements

- Observe  $\geq 2$  square degrees in the Galactic Bulge at  $\leq 15$  minute sampling cadence
- $S/N \geq 100$  for J-band magnitude  $\leq 20.5$  sources
- $\leq 0.3''$  imaging angular resolution
- Multi-color observations at least every  $\sim 12$  hours
- Minimum continuous monitoring time span:  $\sim 60$  days
- Separation of  $\geq 4$  years between first and last observing seasons
  - For detection of source-lens relative proper motion

# Mission Simulations

- From Bennett & Rhie (2002) ApJ 574, 985
- Basic results confirmed by independent simulations by Gaudi
- Galactic Model
  - foreground extinction as a function of galactic position
  - star density as a function of position
  - Stellar microlensing rate as a function of position
- Telescope effective area and optical PSF
- Pixel Scale – contributes to PSF
- Main Observing Passband ~ 1.0-2.0  $\mu\text{m}$ 
  - throughput
  - PSF width
- Observing strategy
  - # of fields
  - Observing cadence
  - Field locations



# Microlensing Optical Depth & Rate

## Optical depth

- Bissantz & Gerhard (2002)  $\tau$  value that fits the EROS, MACHO & OGLE clump giant measurements
- Revised OGLE value is ~20% larger than shown in the plot.
- Observations are ~5 years old

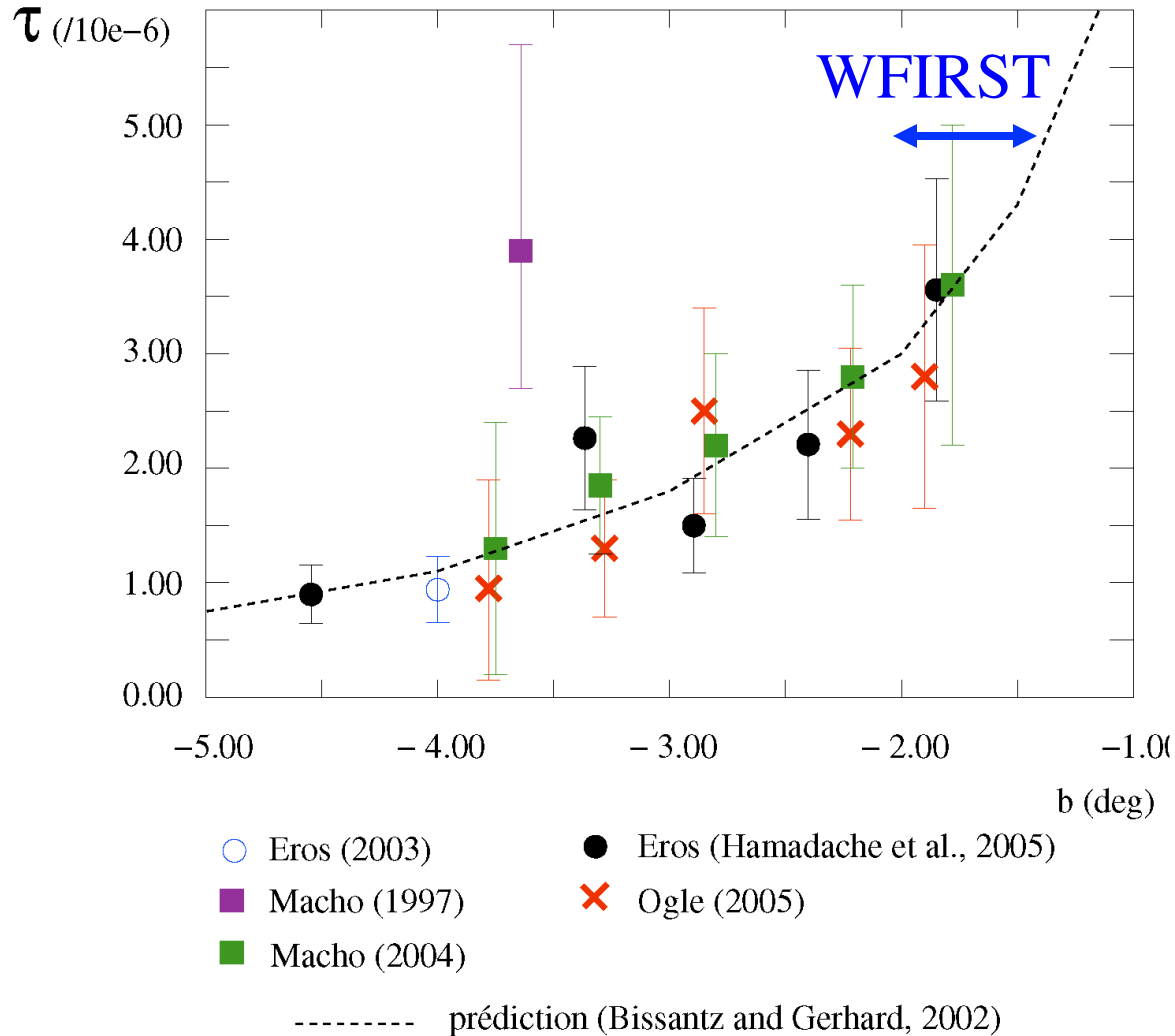

# Select Fields from Microlensing Rate Map (including extinction)

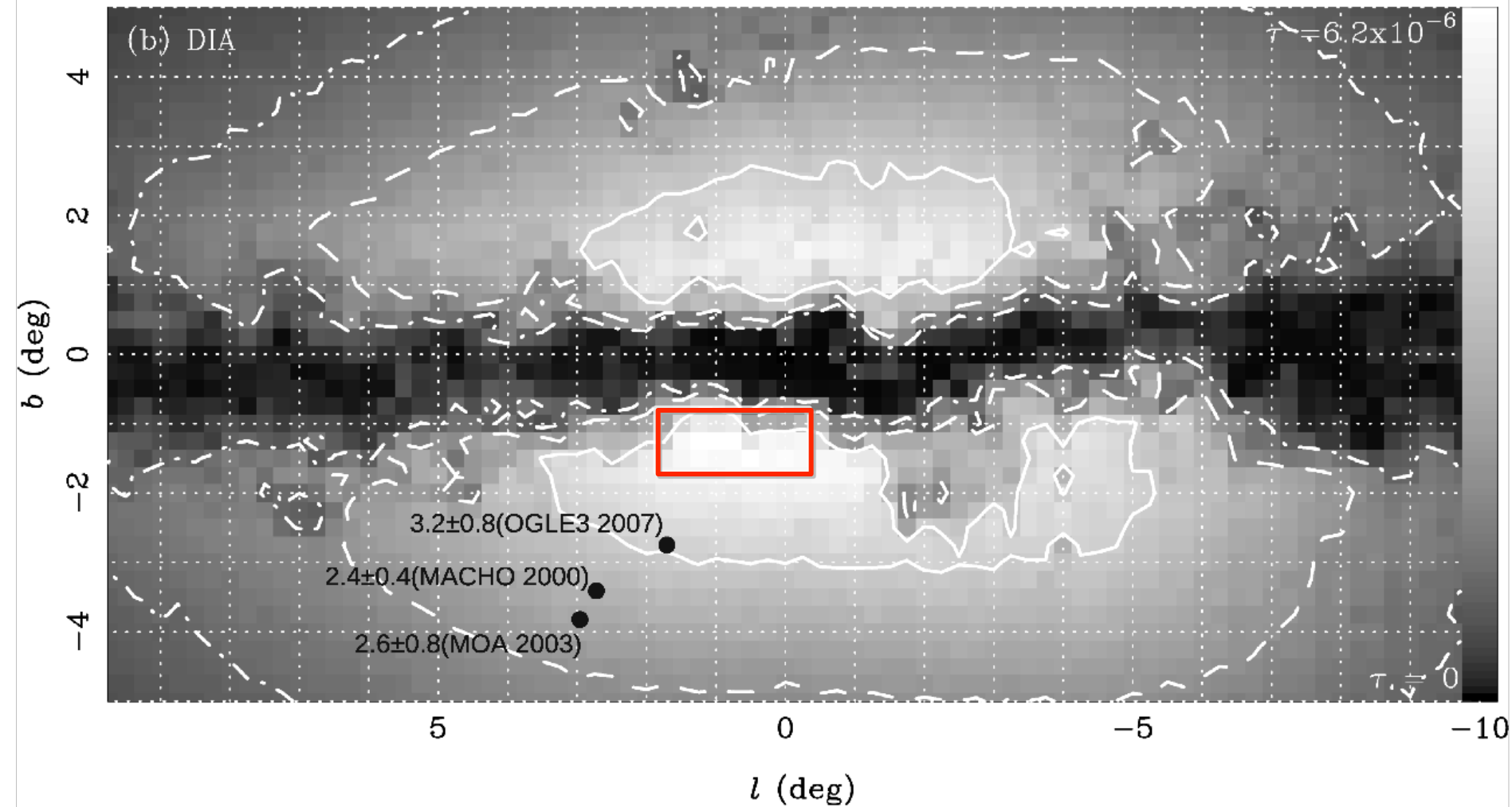

Optical Depth map from Kerins et al. (2009)

# Simulated Planetary Light Curves

- Planetary signals can be very strong
- There are a variety of light curve features to indicate the planetary mass ratio and separation
- Exposures every 10-15 minutes
- The small deviation at day  $-42.75$  is due to a moon of 1.6 lunar masses.

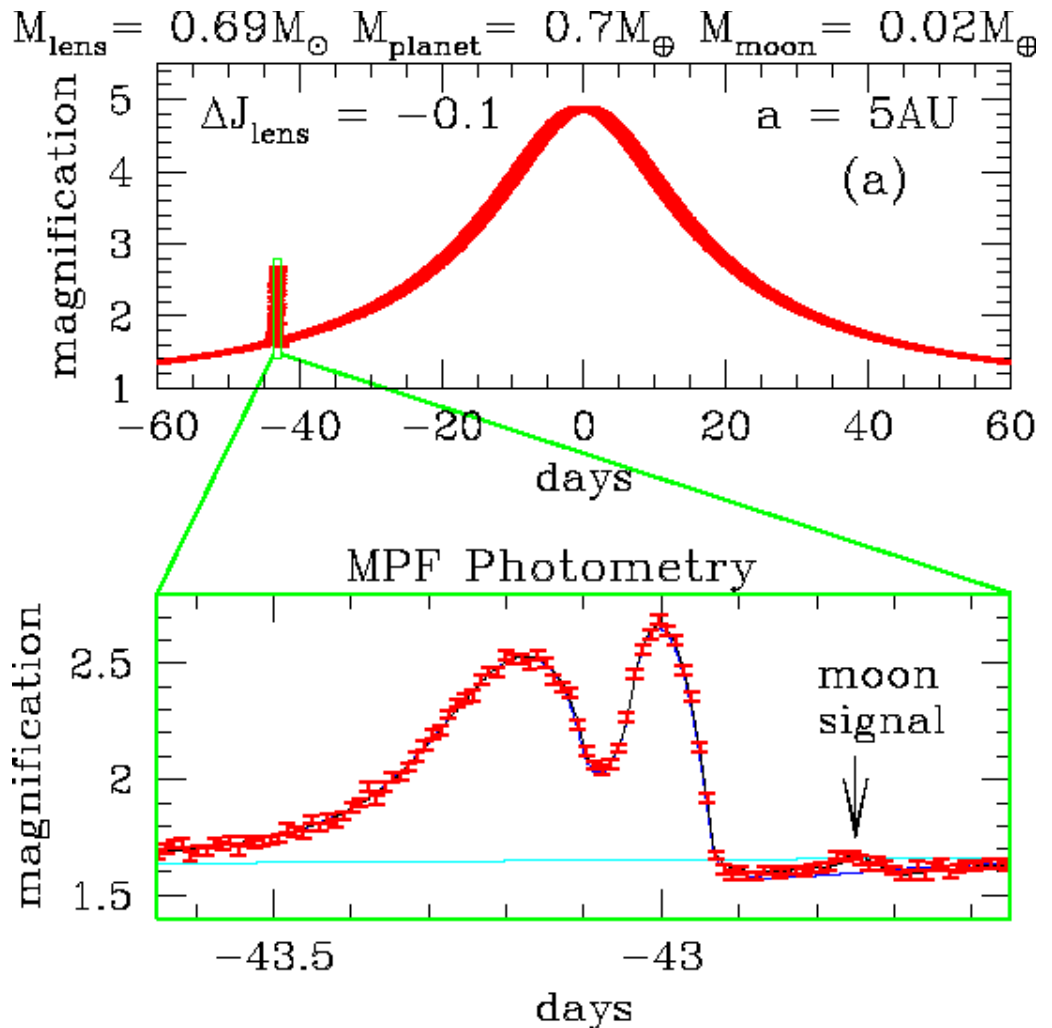

# Simulated **MPF** Light Curves

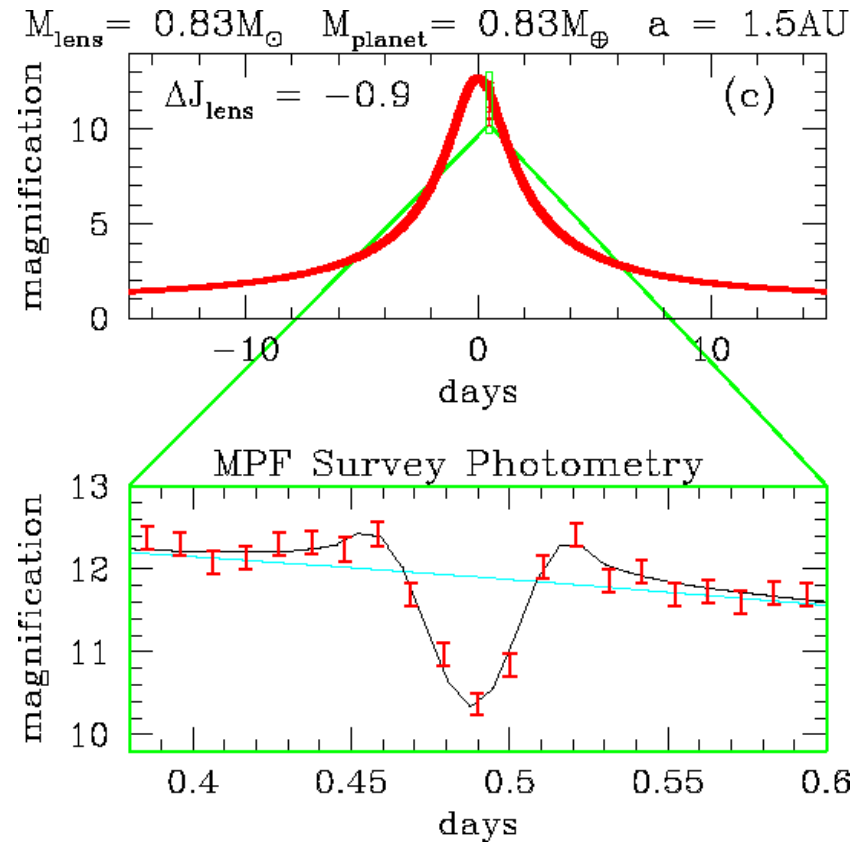
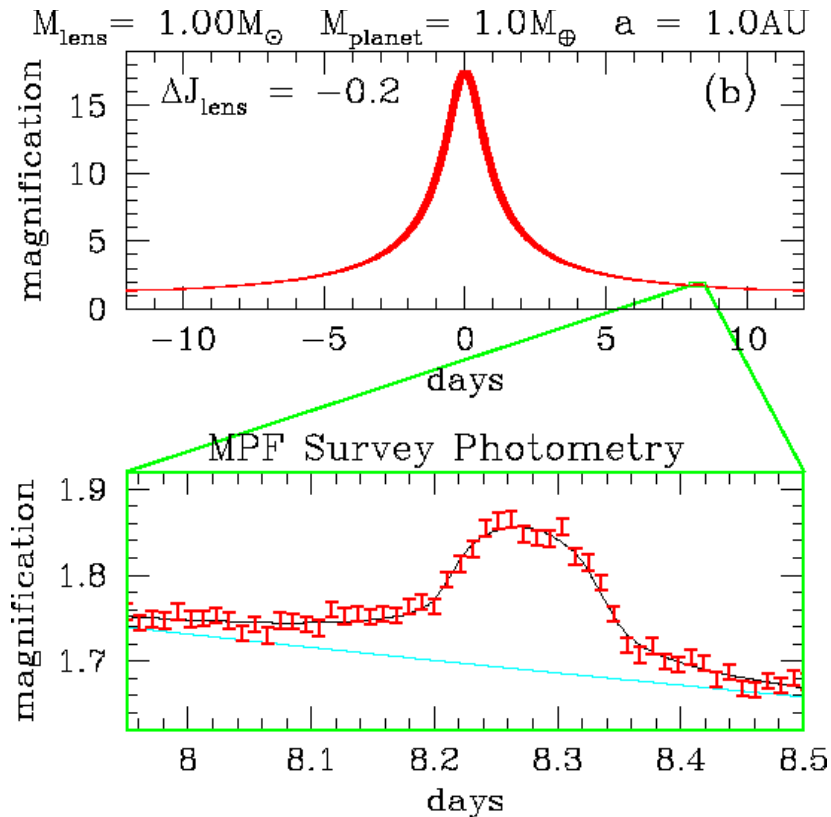

The light curves of simulated planetary microlensing events with predicted MPF error bars.  $\Delta J_{\text{lens}}$  refers to the difference between the lens and source star magnitudes. The lens star is brighter for each of these events.

# Lens System Properties

- For a single lens event, 3 parameters (lens mass, distance, and velocity) are constrained by the Einstein radius crossing time,  $t_E$
- There are two ways to improve upon this with light curve data:
  - Determine the angular Einstein radius :  $\theta_E = \theta_* t_E / t_* = t_E \mu_{\text{rel}}$  where  $\theta_*$  is the angular radius of the star and  $\mu_{\text{rel}}$  is the relative lens-source proper motion
  - Measure the projected Einstein radius,  $\tilde{r}_E$ , with the microlensing parallax effect (due to Earth's orbital motion).

# Lens System Properties

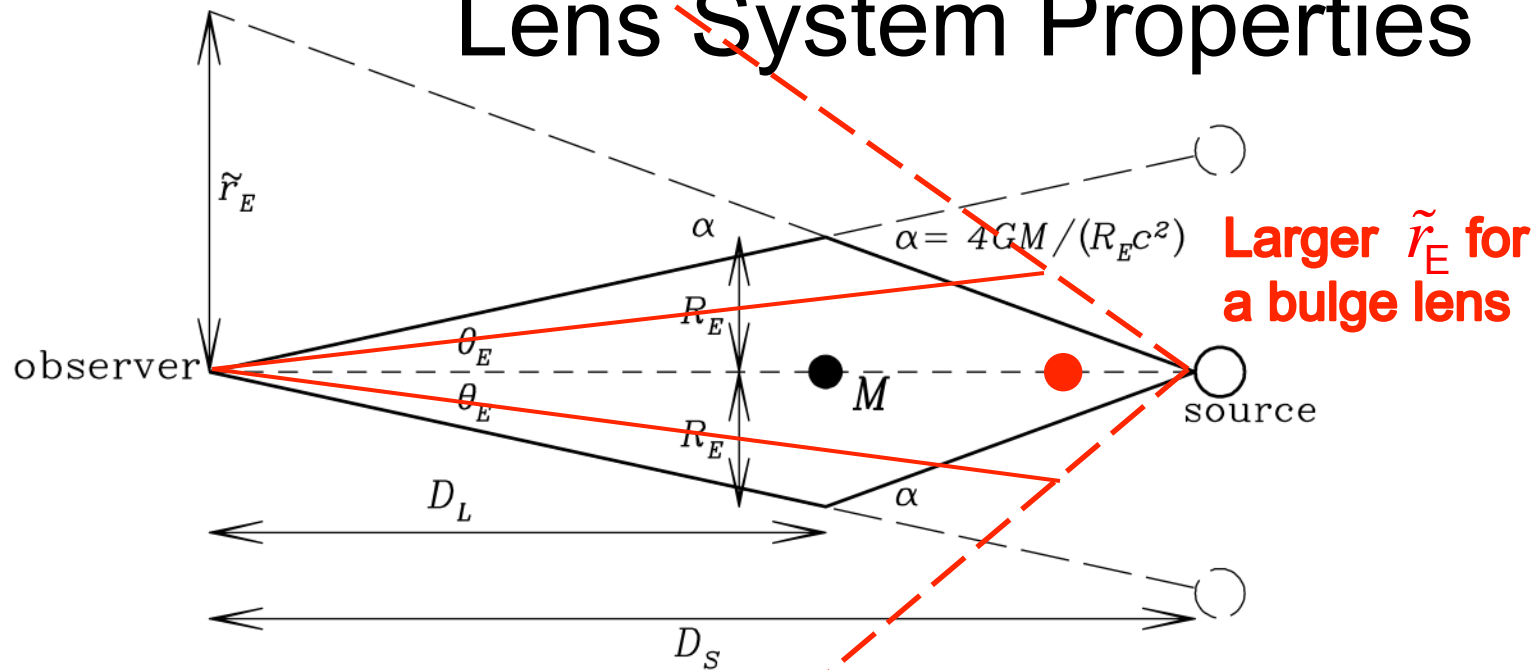

- Einstein radius :  $\theta_E = \theta_* t_E / t_*$  and projected Einstein radius,  $\tilde{r}_E$ 
  - $\theta_*$  = the angular radius of the star
  - $\tilde{r}_E$  from the microlensing parallax effect (due to Earth's orbital motion).

$$R_E = \theta_E D_L, \text{ so } \alpha = \frac{\tilde{r}_E}{D_L} = \frac{4GM}{c^2 \theta_E D_L}. \text{ Hence } M = \frac{c^2}{4G} \theta_E \tilde{r}_E$$

# Finite Source Effects & Microlensing Parallax Yield Lens System Mass

- If only  $\theta_E$  or  $\tilde{r}_E$  is measured, then we have a mass-distance relation.
- Such a relation can be solved if we detect the lens star and use a mass-luminosity relation
  - This requires HST or ground-based adaptive optics
- With  $\theta_E$ ,  $\tilde{r}_E$ , and lens star brightness, we have more constraints than parameters

mass-distance relations:

$$M_L = \frac{c^2}{4G} \theta_E^2 \frac{D_S D_L}{D_S - D_L}$$

$$M_L = \frac{c^2}{4G} \tilde{r}_E^2 \frac{D_S - D_L}{D_S D_L}$$

$$M_L = \frac{c^2}{4G} \tilde{r}_E \theta_E$$

# Lens Star Detection in **WFIRST** Images

- The typical lens-source relative proper motion is  $\mu_{\text{rel}} \sim 5 \text{ mas/yr}$
- This gives a total motion of  $>0.11$  pixels over 4 years
- This is directly detectable in co-added WFIRST images due to WFIRST's stable PSF and large number of images of each of the target fields.
- $\mu_{\text{rel}}$  is also determined from the light curve fit.
- A color difference between the source and lens stars provides a signal of  $\mu_{\text{rel}}$  in the color dependence of the source+lens centroid position

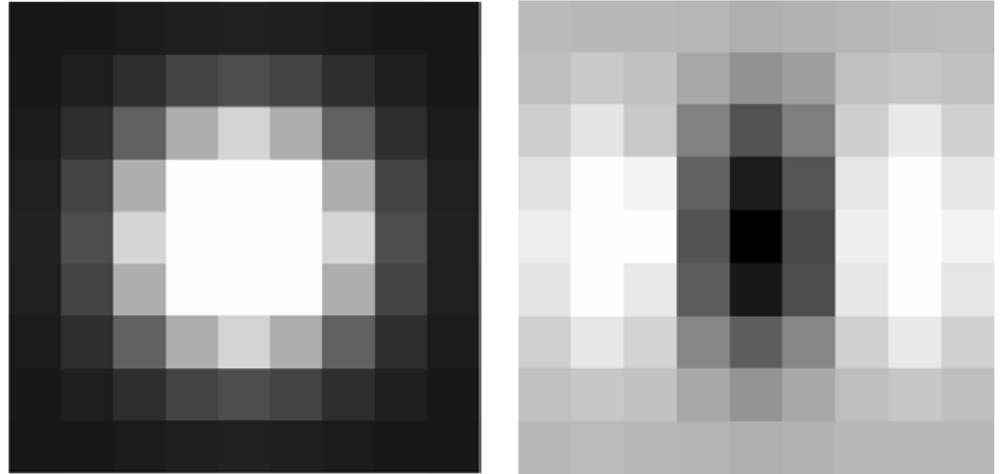

A  $3\times$  super-sampled, drizzled 4-month WFIRST image stack showing a lens-source blend with a separation of 0.07 pixel, is very similar to a point source (left). But with PSF subtraction, the image elongation becomes clear, indicating measurable relative proper motion.



# Lens Star Identification from Space

- Lens-source proper motion gives  $\theta_E = \mu_{\text{rel}} t_E$
- $\mu_{\text{rel}} = 8.4 \pm 0.6$  mas/yr for OGLE-2005-BLG-169
- Simulated HST ACS/HRC F814W (*I*-band) single orbit image “stacks” taken 2.4 years after peak magnification
  - 2× native resolution
  - also detectable with HST WFPC2/PC & NICMOS/NIC1
- Stable HST PSF allows clear detection of PSF elongation signal
- A main sequence lens of any mass is easily detected (for this event)

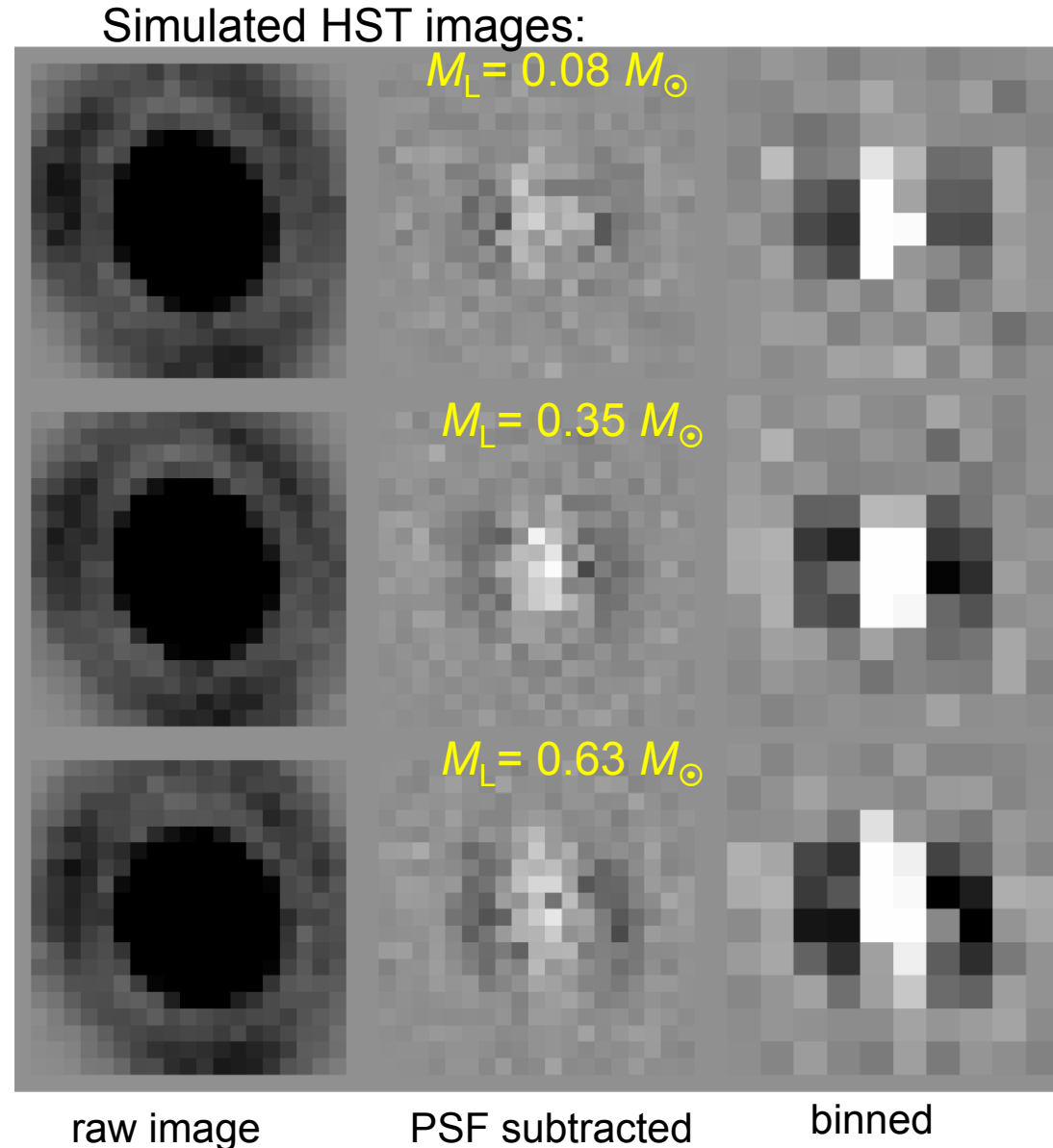

# Color Dependent Image Center Shift

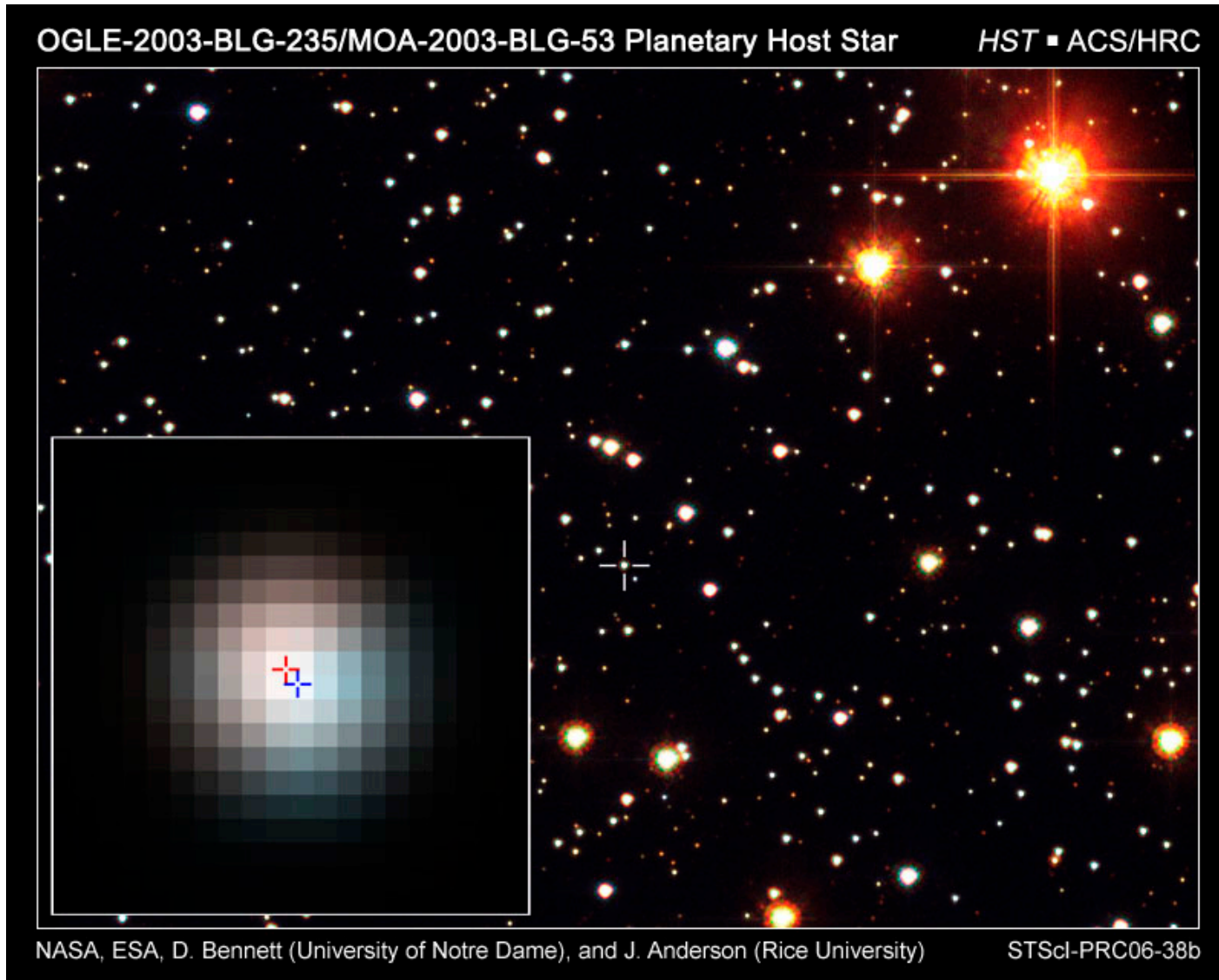

Source & Planetary Host stars usually have different colors, so lens-source separation is revealed by different centroids in different passbands

# HST Image Centroids in B, V, I for OGLE-2003-BLG-235L

Relative proper motion

$\mu_{\text{rel}} = 3.3 \pm 0.4$  mas/yr

from light curve

analysis ( $\mu_{\text{rel}} = \theta_*/t_*$ )

1.8 years after event

=> 5.9 mas lens-source  
separation

centroid offsets:

B-I  $\sim 0.6$  mas

V-I  $\sim 0.4$  mas

B-V  $\sim 0.2$  mas

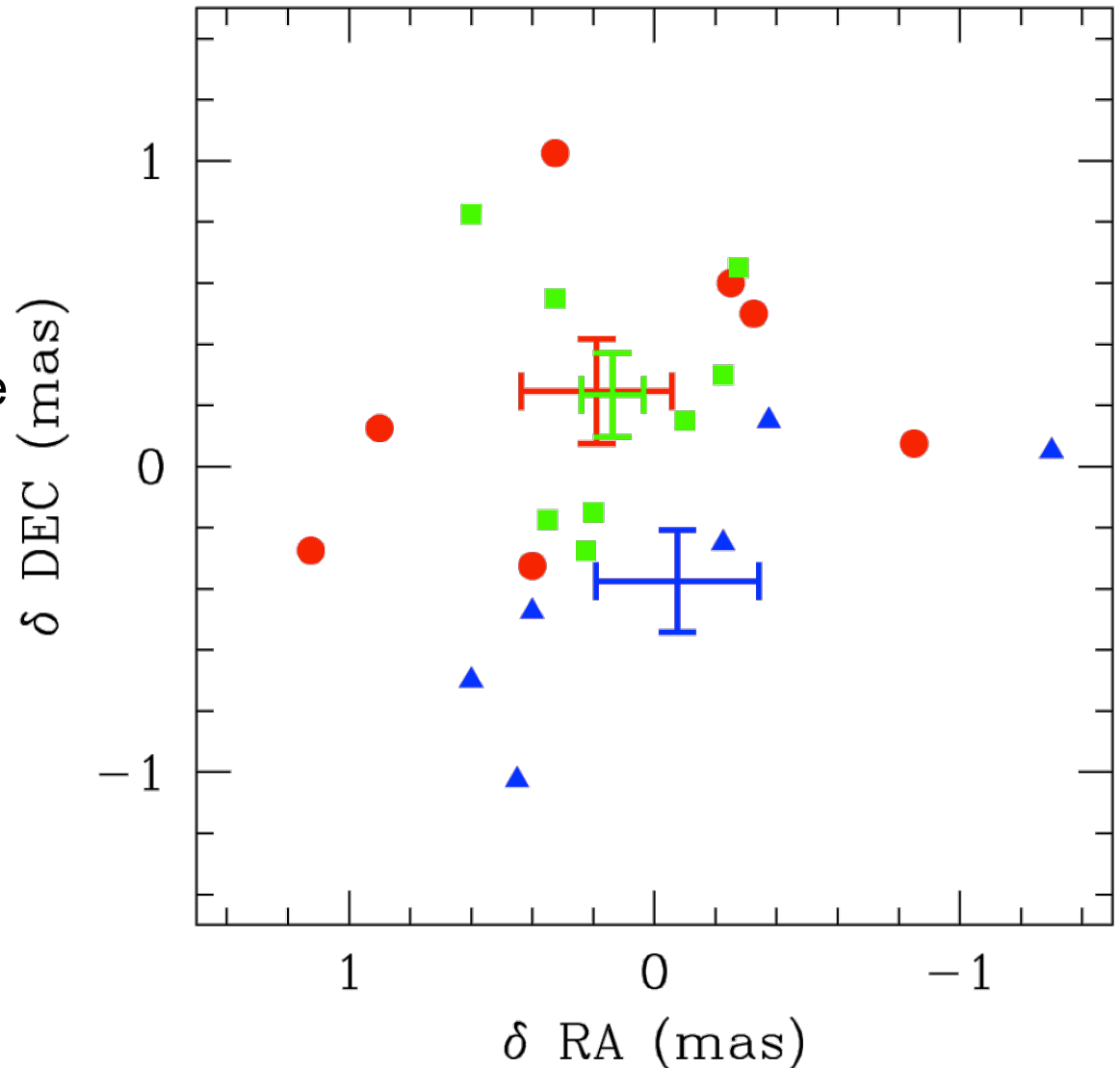

# HST Observation Predictions for OGLE-2003-BLG-235L/MOA-2003-BLG-53L

Fraction of total flux  
due to lens star.

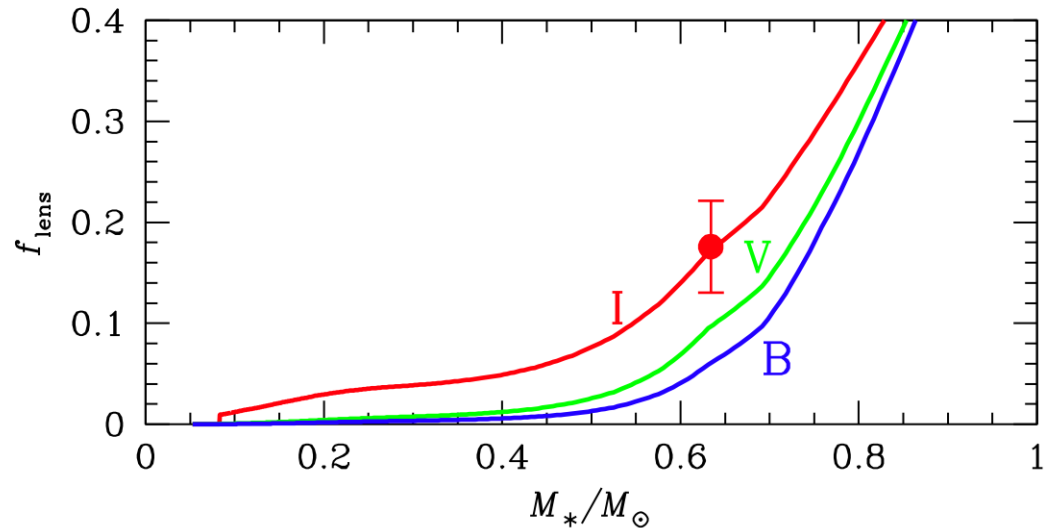

Centroid Shift  
between HST-ACS/  
HRC passbands for  
follow-up images.

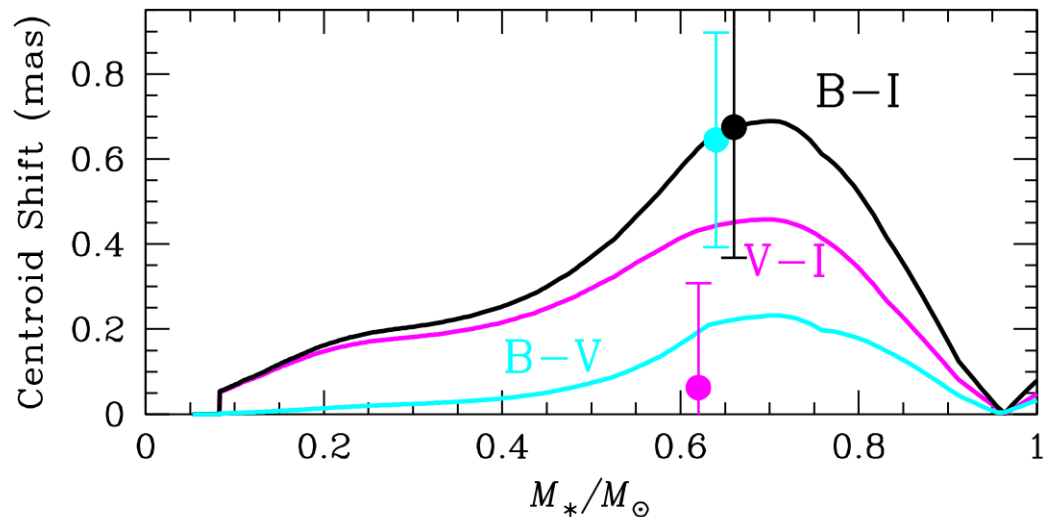

Relative proper motion  $\mu_{\text{rel}} = 3.3 \pm 0.4$  mas/yr  
from light curve analysis ( $\mu_{\text{rel}} = \theta_*/t_*$ )

# HST Follow-up

- More details in Jay Anderson's talk
- Difficult to get HST time
  - No microlensers on the TAC
  - Fewer exoplanet proposals than in other fields
  - Time allocations determined by proposal pressure
- Probably difficult to get HST (or JWST) follow-up for most discoveries by next generation ground-based programs

# Lens Detection Provides Complete Lens Solution

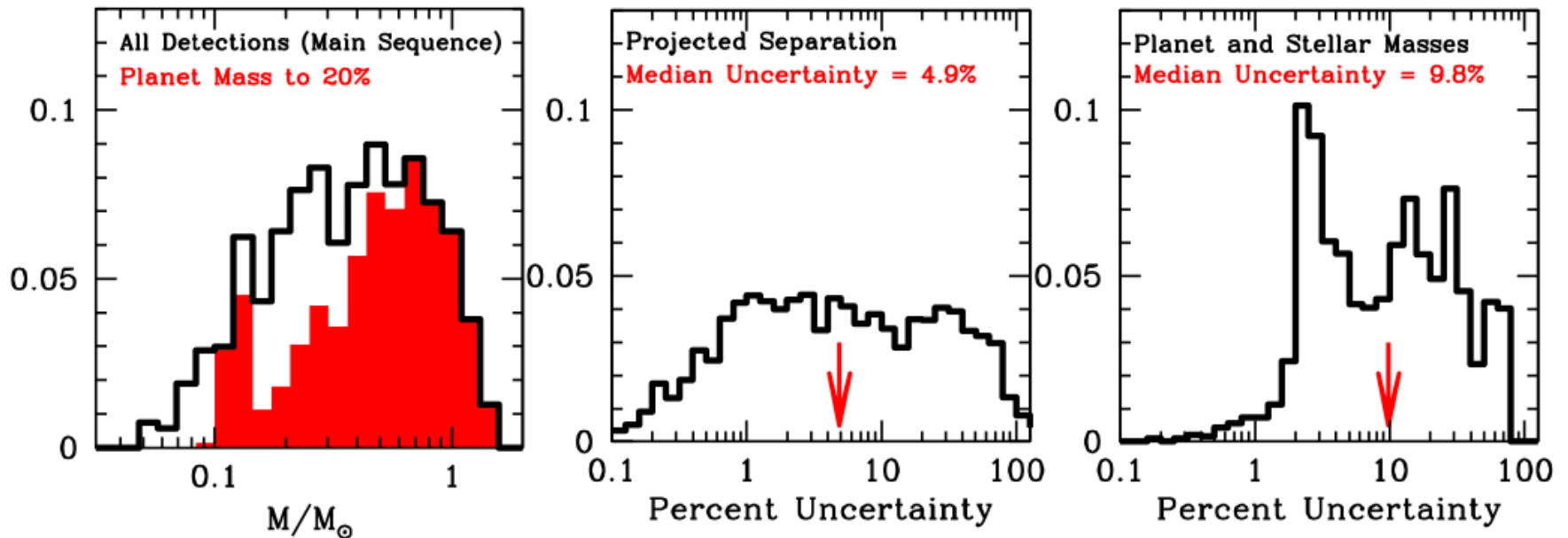

- The observed brightness of the lens can be combined with a mass-luminosity relation, plus the mass-distance relation that comes from the  $\mu_{\text{rel}}$  measurement, to yield a complete lens solution.
- The resulting uncertainties in the absolute planet and star masses and projected separation are shown above.
- Multiple methods to determine  $\mu_{\text{rel}}$  and masses (such as lens star color and microlensing parallax) imply that complications like source star binarity are not a problem.

# Space-Based Exoplanet Microlensing History (1)

- 1994 – Alcock suggests wide FOV space telescope to search for dark matter microlensing toward many Local Group galaxies – no proposal
- 1995 – Dark Object Microlens Explorer (DOME) – 30cm microlensing parallax satellite proposed by Alcock et al. to Midex – lost to WMAP
- (1999 SuperNova Anisotropy Probe (SNAP) concept - wide FOV w/ IR optimized CCDs)
- 2000 – 1<sup>st</sup> Galactic Exoplanet Survey Telescope (GEST) Discovery proposal – PI: Bennett
  - Discovery was only for planets or exoplanets – no Dark Energy
  - Wide FOV 1.5m telescope w/ IR optimized CCDs
  - Basis for Bennett & Rhie (2002) space-based microlensing
  - based on suggestion from John Mather in 1998

# Space-Based Exoplanet Microlensing History (2)

- 2001 – GEST Midex Proposal
  - 1<sup>st</sup> Joint Exoplanet Microlensing + Dark energy proposal
  - D.E. program:
    - Weak lensing and Supernova (type 1a) w/ JWST spectra
  - Col's included Jason Rhodes, Tod Lauer, Peter Garnavich
  - Yannick Mellier (Euclid PI) also worked on this
  - 1.1m telescope w/ IR Optimised CCDs
  - Didn't credibly fit the Midex Cost-cap
- 2003 – Deep Impact Microlens Explorer (DIME)
  - First ever New Science Extended mission proposal
    - led to EXPOXI mission
  - Microlens Parallax Observations primarily of Magellanic Cloud events
  - Strong Science review – but no JPL endorsed budget
  - “likely” to be selected in 2004 Midex competition – which was then canceled



# Space-Based Exoplanet Microlensing History (3)

- 2004 – Microlensing Planet Finder (MPF) Discovery proposal
  - 70 2k×2k HgCdTe IT detectors 1.1m telescope
  - Top rated science, but rated high risk
- 2006 – 2<sup>nd</sup> MPF Discovery Proposal
  - 35 2k×2k HgCdTe IT detectors 1.1m telescope
  - Down to medium risk – but science rated poor
    - led to policy change – future reviews are written not oral
- 2007 Dark UNiverse Explorer (DUNE) - Refregier et al.
  - Exoplanet Microlensing is a secondary science program
  - Combined with SPACE to make Euclid
- 2008 – ExoPlanet Task Force (ExoPTF) report
  - conditional endorsement: fly an exoplanet microlensing mission if it doesn't impact an astrometry mission
- 2010 – New Worlds, New Horizons decadal survey

# Astro-2010 Decadal Survey

“**WFIRST** designed to settle important questions in both exoplanet and dark energy research”

“the Kepler satellite ... should be capable of detecting Earth-size planets out to almost Earth-like orbits.”

“As microlensing is sensitive to planets of all masses having orbits larger than about half of Earth’s, WFIRST would be able to complement and complete the statistical task underway with Kepler, resulting in an unbiased survey of the properties of distant planetary systems.

**WFIRST** does a microlensing planet search, multiple dark energy studies plus IR surveys and GO observations



# Rationale for Joint Exoplanet/Dark Energy mission

- Telescope designed for DE mission can do the exoplanet microlensing with only trivial modifications
  - thermal and power design for continuous Galactic bulge observations
  - Exoplanet survey requirements are much less stringent than DE requirements, so a wide variety of DE mission designs can do the exoplanet survey
    - including JDEM- $\Omega$  and Euclid
- JDEM and MPF have been proposed with a single purpose for political reasons only
  - NASA Discovery program considered only solar system and exoplanet missions
  - DOE and Beyond Einstein consider only cosmology

# WFIRST

Wide-Field Infra-Red Survey Telescope

## SDT

### Science Definition Team (SDT) Membership

J. Green, Colorado/CASA

R. Bean, Cornell University,

C. Bennett, JHU

**R. Brown, STScI**

M. Donahue, Michigan State

**T. Lauer, NOAO\***

S. Perlmutter, UCB / LBNL

**J. Rhodes, JPL\***

D. Stern, JPL

**A. Tanner, Georgia State Univ.**

E. Wright, UCLA

N. Gehrels, GSFC (Ex-Officio)

R. Sambruna, NASA HQ (Ex-Officio)

**W. Traub, JPL (Ex-Officio)**

P. Schechter, MIT (Co-Chairs)

C. Baltay, Yale

**D. Bennett, Notre Dame**

C. Conselice, Nottingham

**S. Gaudi, Ohio State**

B. Nichol, Portsmouth

B. Rauscher, GSFC

T. Roellig, Ames

**T. Sumi, Osaka Univ.**

Y. Wang, Oklahoma

\*Co-I's on original  $\mu$ lensing exoplanet + DE  
proposal: GEST

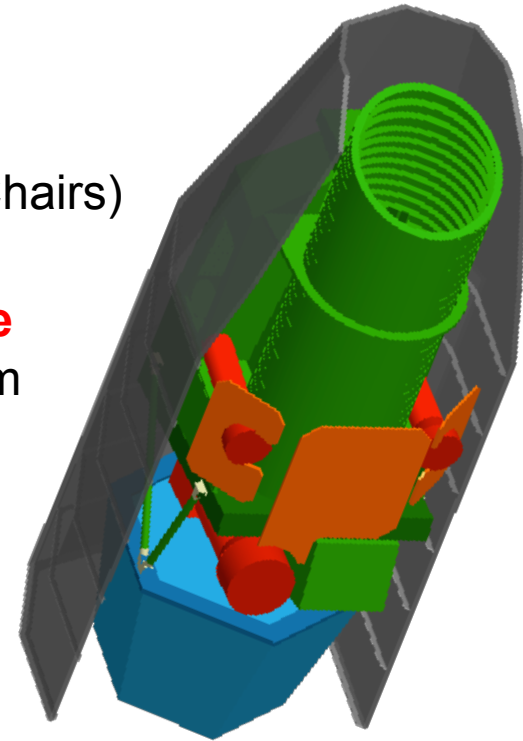

more info: <http://wfirst.gsfc.nasa.gov/>

# SDT Reports

- Interim Design Reference Mission report just submitted
  - Generate WFIRST mission concept
    - w/ science program from NWNH
  - Basis for 1<sup>st</sup> cost estimate
  - Basis for negotiations with Euclid
  - Basis for descope comparisons
- Informal Advice for discussions with Euclid
- Final Report – due in 2012
  - More serious attempt at cost reduction
  - More consideration of joint mission, etc.

# WFIRST's Predicted Discoveries

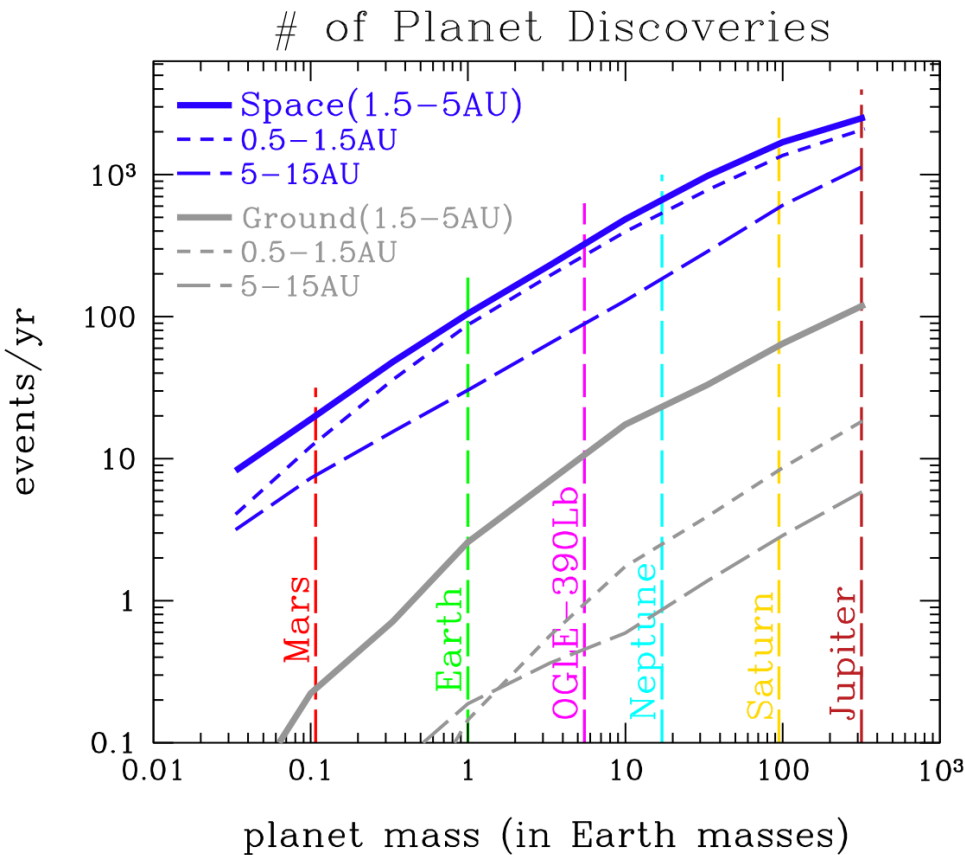

The number of expected WFIRST planet discoveries per 8-month observing season as a function of planet mass.

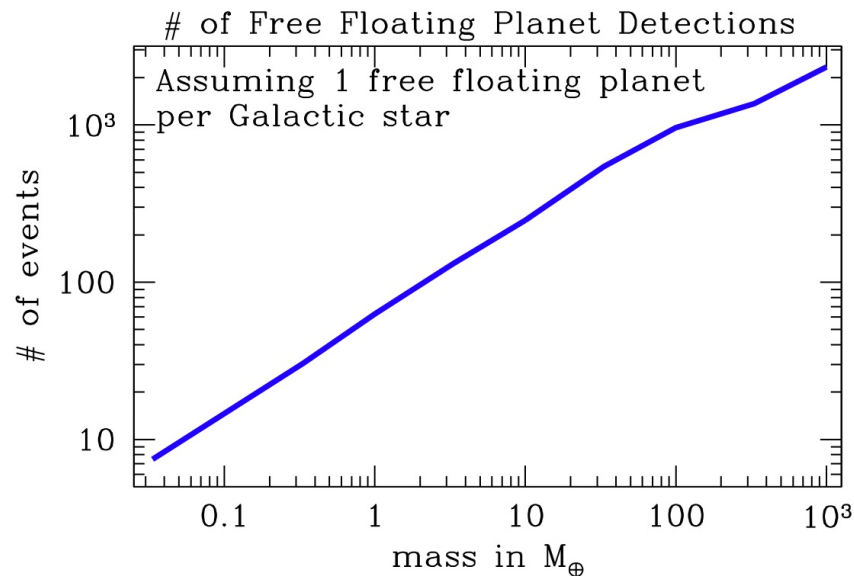

Current exoplanet statistics imply:

- 3250 exoplanet discoveries
  - 320 w/  $M < 1 M_{\oplus}$
  - 1050 w/  $M < 10 M_{\oplus}$
- 2080 free-floating exoplanets
  - 190 w/  $M < 1 M_{\oplus}$
  - 480 w/  $M < 10 M_{\oplus}$

# WFIRST Top-Level Science Objectives

1. Complete the census of exoplanets from Earth-like planets in the habitable zone to free-floating planets.
2. Determine the expansion history of the Universe and its growth of structure so as to test explanations of its acceleration such as Dark Energy and modifications to Einstein's gravity.
3. Serendipitously survey the NIR sky at wavelengths that detect the bulk of the star formation history of the Universe.

# Planet Discoveries by Method

- ~400 Doppler discoveries in black
- Transit discoveries are blue squares
- Gravitational microlensing discoveries in red
  - cool, low-mass planets
- Direct detection, and timing are magenta and green triangles
- Kepler candidates are cyan spots

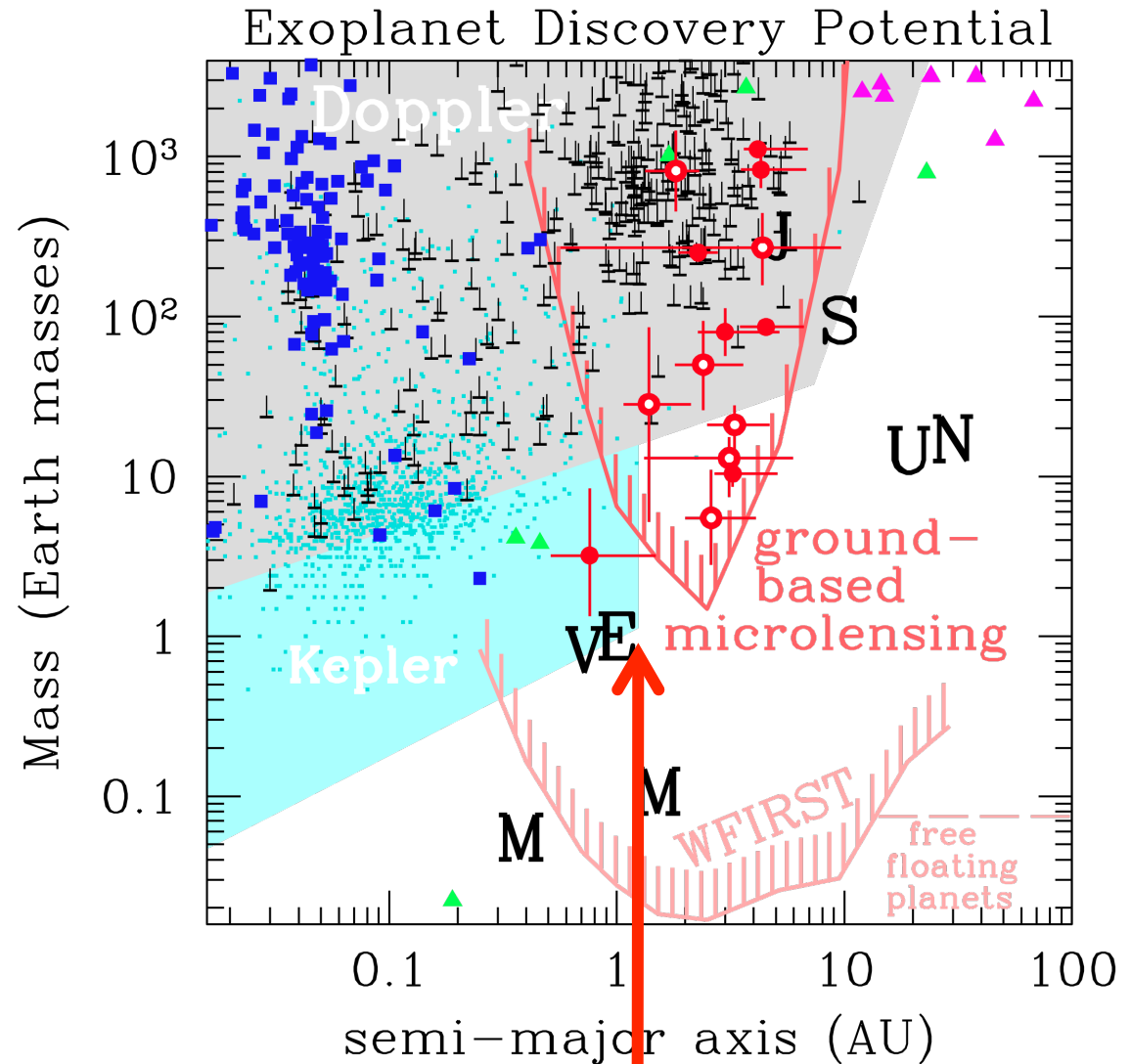

Fill gap between  
Kepler and ground ML



# Planet mass vs. semi-major axis/snow-line

- “snow-line” defined to be 2.7 AU ( $M/M_{\odot}$ )
  - since  $L \propto M^2$  during planet formation
- Microlensing discoveries in **red**.
- Doppler discoveries in black
- Transit discoveries shown as **blue circles**
- Kepler candidates are **cyan spots**
- Super-Earth planets beyond the snow-line appear to be the most common type yet discovered

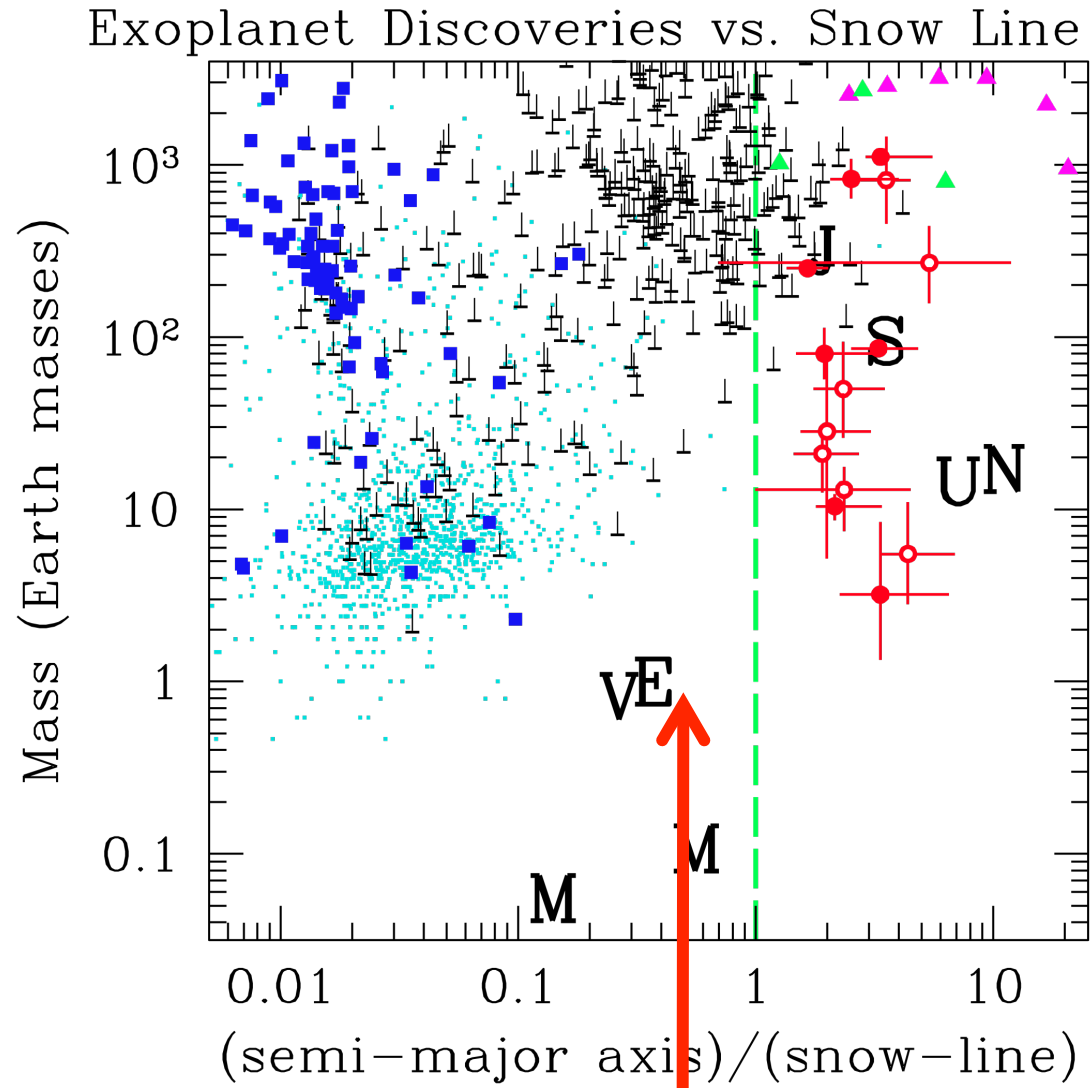

Fill gap between  
Kepler and ground ML

# WFIRST's Predicted Discoveries

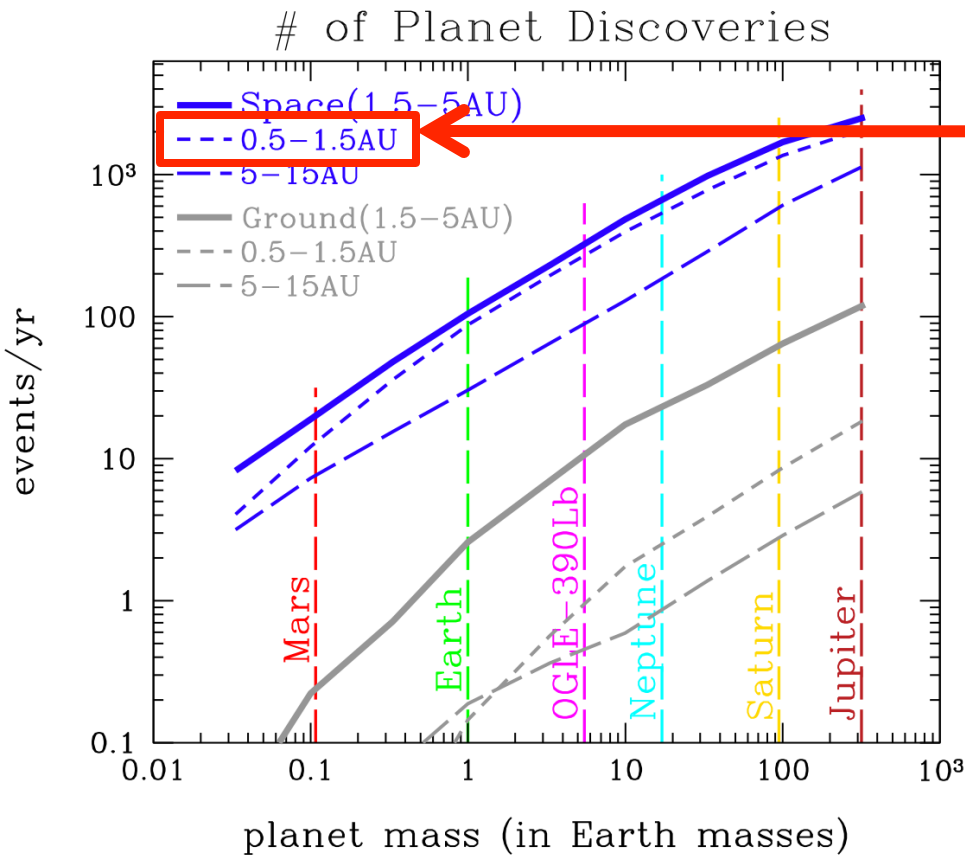

Pick a separation range that cannot be done from the ground; wider separation planets will also be detected.

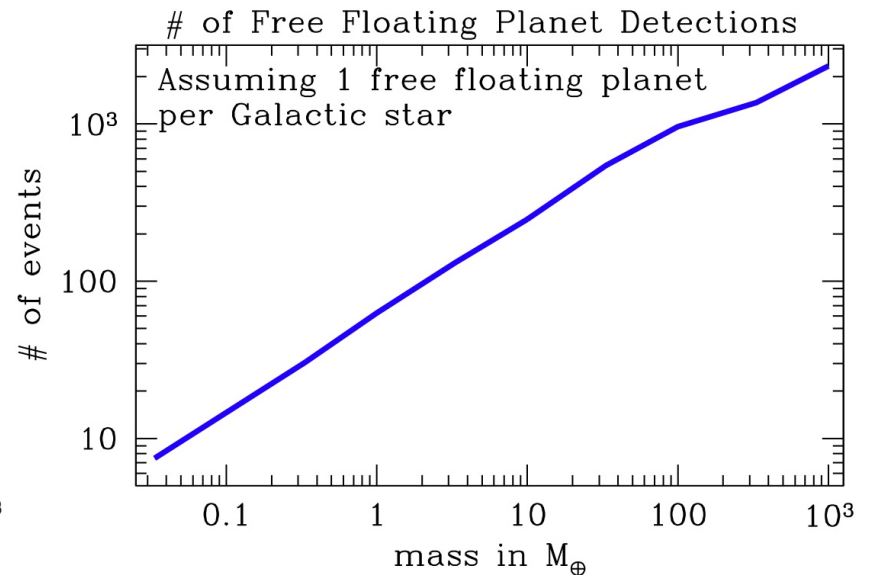

The number of expected WFIRST planet discoveries per 9-months of observing as a function of planet mass.

# WFIRST Microlensing Figure of Merit

- FOM1 - # of planets detected for a particular mass and separation range
  - Cannot be calculated analytically – must be simulated
    - Analytic models of the galaxy (particularly the dust distribution) are insufficient
  - Should not encompass a large range of detection sensitivities.
  - Should be focused on the region of interest and novel capabilities.
  - Should be easily understood and interpreted by non-microlensing experts
    - (an obscure FOM understood only by experts may be ok for the DE programs, but there are too few microlensing experts)
- FOM2 – habitable planets - sensitive to Galactic model parameters
- FOM3 – free-floating planets – probably guaranteed by FOM1
- FOM4 – number of planets with measured masses
  - Current calculations are too crude

# Figure of Merit

$$FOM \equiv (N_{\oplus} N_{HZ} N_{ff} N_{20\%})^{3/8} \propto T^{3/2}$$

1.  $N_{\oplus}$ : Number of planets detected (at  $\Delta\chi^2=160$ ) with a  $M=M_{\oplus}$  and  $P = 2$  yr, assuming every MS star has one such planet.
  - Region of parameter space difficult to access from the ground.
  - Uses period rather than semimajor axis as  $P/R_E$  is a weaker function of primary mass than  $a/R_E$ .
  - Designed to be diagnostic of the science yield for the experiment. If mission can detect these planets, guaranteed to detect more distant planets
2.  $N_{HZ}$ : Number of habitable planets detected assuming every MS star has one, where habitable means  $0.5-10M_{\text{Earth}}$ , and  $[0.72-2.0 \text{ AU}](L/L_{\text{sun}})^{1/2}$
3.  $N_{ff}$ : The number of free-floating  $1M_{\text{Earth}}$  planets detected, assuming one free floating planet per star.
4.  $N_{20\%}$ : The number of planets detected with a  $M=M_{\text{Earth}}$  and  $P=2$  yr for which the primary mass can be determined to 20%.

